



Lester Electrical

LESTRONIC II BATTERY CHARGER MODEL 07850 TYPE 36LC25-8ET

Specifications

AC Input:	105-128 Volts AC, 60 Hertz, single-phase, 13 Amps Max
DC Output:	36 Volts DC, 25 Amps tapering to 8 Amps at 45 Volts DC
Connections:	8½ ft. DC cord with connecting plug standard; optional plugs and cord lengths available
Dimensions:	10-1/6 H x 8-11/16 W x 9-1/2 D
Mounting:	Set on shelf, wall mount with keyholes, or hang from ceiling securely.

PLEASE SAVE THESE IMPORTANT SAFETY AND OPERATING INSTRUCTIONS

For correct operation of the equipment, it is important to read and be familiar with this entire manual before installing and operating the charger.
DO NOT DISCARD THIS MANUAL AFTER READING.



LOOK FOR THIS SYMBOL TO POINT OUT SAFETY PRECAUTIONS. IT MEANS: BECOME ALERT—YOUR SAFETY IS INVOLVED. IF YOU DO NOT FOLLOW THESE SAFETY INSTRUCTIONS, INJURY OR PROPERTY DAMAGE CAN OCCUR.

Features

- Patented electronic timer monitors battery state of charge and automatically turns charger off at full charge.
- Line voltage compensation achieved by flux oscillator circuit applied to battery charger for high reliability "Minute Man" missile standby applications. Compensates automatically for AC supply voltage variations. Supply voltage variation $\pm 10\%$ from nominal = $\pm 1\%$ maximum battery voltage variation, decreasing to $\pm \frac{1}{2}\%$ at finish rate with constant electrolyte temperature. No taps or rate controls to set.
- Automatic taper of charge rate for superior battery life through good equalization of cells and low water use rate.
- Silicon diodes with inherent surge protection operation at a conservative percentage of their rating.
- Convection cooled design for maximum reliability and minimum maintenance.

INTRODUCTION

The Lestronic II battery charger is designed to recharge deep-cycle, lead acid batteries. A ferroresonant transformer is used to provide a highly reliable, line compensating unit with a minimum of moving parts, designed for long, trouble-free service. A patented electronic timer turns the charger on and off automatically. This electronic timer determines full charge of the batteries by measuring the rate at which the battery voltage increases during charge. When the voltage stops rising, the battery is fully charged and the charger turns off.

INITIAL INSTALLATION

The AC line to which the charger is to be connected must be capable of supplying 15 amperes to this charger.

 CAUTION: TO REDUCE THE RISK OF FIRE, USE THIS CHARGER ONLY ON CIRCUITS PROVIDED WITH A MAXIMUM OF 20 AMPERE BRANCH CIRCUIT PROTECTION (CIRCUIT BREAKER OR FUSE), IN ACCORDANCE WITH THE NATIONAL ELECTRICAL CODE, ANSI/NFPA 70, AND ALL LOCAL CODES AND ORDINANCES.

The use of an extension cord with the charger should be avoided. The use of an improper extension cord could result in a risk of fire or electric shock. If an extension cord must be used, use a three-conductor, No. 12 AWG cord with ground, properly wired, in good electrical condition and keep it as short as possible. Make sure that the pins on the plug of the extension cord are the same number, size, and shape as that of the plug on the battery charger. Locate all cords so that they will not be stepped on, tripped over, or otherwise subjected to damage or stress.

Do not operate this charger if it has received a sharp blow, was dropped, or otherwise damaged in any manner; refer to a qualified service agent.

Provide adequate ventilation for the batteries and charger. The convection-cooled design requires an unobstructed flow of cooling air for proper operation. Keep all charger ventilation openings at least two inches (2") (5cm) away from walls and other objects. Do not allow clothing, blankets, or other material to cover the charger.

⚠ WARNING: CHARGERS CAN IGNITE FLAMMABLE MATERIALS AND VAPORS. DO NOT USE NEAR FUELS, GRAIN DUST, SOLVENTS, OR OTHER FLAMMABLES.

⚠ WARNING: TO REDUCE THE RISK OF ELECTRIC SHOCK, KEEP THE CHARGER DRY. DO NOT EXPOSE IT TO RAIN. FOR STORAGE, KEEP CHARGER IN A BUILDING.

GROUNDING INSTRUCTIONS

This battery charger must be grounded to reduce the risk of electric shock. This charger is equipped with an electric cord having an equipment-grounding conductor and a grounding type plug and is for use on a nominal 115 volt, 60 Hertz circuit. This plug must be connected to an appropriate receptacle that is properly installed and grounded in accordance with the National Electrical Code and all local codes and ordinances.

⚠ WARNING: IMPROPER CONNECTION OF THE EQUIPMENT-GROUNDING CONDUCTOR CAN RESULT IN RISK OF ELECTRIC SHOCK.

The conductor with insulation having an outer surface that is green, with or without yellow stripe(s), is the equipment-grounding conductor. If repair or replacement of the electric cord or plug is necessary, do not connect the equipment-grounding connector to a live terminal. Refer to a qualified service agent.

A temporary adapter, as illustrated in Figures B and C, may be used to connect this plug to a two-pole outlet as shown in Figure C if a properly grounded outlet is not available. The temporary adapter should be used only until a properly grounded outlet

can be installed by a qualified electrician. The green-colored rigid ear or lug extending from the adapter must be connected to a permanent ground such as a properly grounded outlet box.

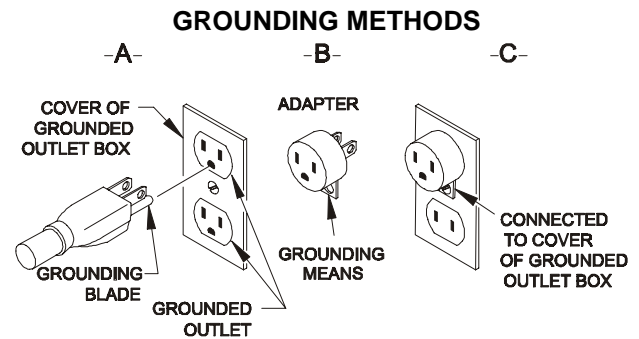

NOTE: The use of the adapter shown in Figures B and C is not permitted in Canada.

NORMAL OPERATION

The instructions printed on the charger are for daily reference.

1. With the charger DC cord disconnected from the batteries, connect the power supply cord to a 115 volt, 60 Hertz circuit.

⚠ WARNING: TO REDUCE THE RISK OF ELECTRIC SHOCK, CONNECT ONLY TO A PROPERLY GROUNDED, SINGLE-PHASE (3-WIRE) OUTLET. REFER TO GROUNDING INSTRUCTIONS.

⚠ CAUTION: MAKE SURE THE BATTERY PACK IS A 36-VOLT, 18 CELL, SERIES CONNECTED LEAD-ACID SYSTEM WITH A CAPACITY OF 180 TO 230 AMPERE-HOURS (20 HR. RATING) OR 85 TO 110 MINUTES (BCI RATING). THE FINISH ON-CHARGE BATTERY VOLTAGE SHOULD BE 2.5 TO 2.6 VOLTS PER CELL. DAMAGE TO THE CHARGER AND BATTERIES MAY RESULT IF THIS CHARGER IS USED ON THE WRONG BATTERIES.

⚠ WARNING: DO NOT TOUCH THE BATTERY TERMINALS OR BLADES ON THE DC OUTPUT PLUG. AN ELECTRIC SHOCK COULD RESULT.

⚠ WARNING: MAKE SURE THE DC OUTPUT PLUG AND BATTERY RECEPTACLE ARE IN GOOD WORKING CONDITION.

DO NOT USE THIS CHARGER IF:

- The DC output plug is too loose or does not make a good connection.
- The DC output plug and receptacle feel hotter than normal.
- The DC output plug blades or receptacle contacts are bent or corroded.

- The DC output plug, receptacle or cords are cut, worn, or have any exposed wires.
- The DC output plug, cords, charger, or receptacle are damaged.

Using this charger with any of the above symptoms could result in a fire, property damage, or personal injury.

Have your distributor, dealer or other qualified service agent repair or replace worn or damaged parts immediately. Repairs should not be attempted by people who are not qualified.

2. Connect the DC output plug to the battery receptacle by grasping the plug body or handle and pushing the plug straight into the receptacle. The charger will start automatically in three to five (3-5) seconds.

⚠ WARNING: DO NOT DISCONNECT THE DC OUTPUT CORD FROM THE BATTERY RECEPTACLE WHEN THE CHARGER IS ON. THE RESULTING ARCING AND BURNING OF THE PLUG AND RECEPTACLE COULD CAUSE THE BATTERIES TO EXPLODE. IF THE CHARGER MUST BE STOPPED, FIRST DISCONNECT THE AC POWER SUPPLY CORD FROM ITS OUTLET, THEN DISCONNECT THE CHARGER DC OUTPUT PLUG FROM THE BATTERY RECEPTACLE.

3. Monitor the ammeter for the correct charge rate. The initial charge rate will vary from 20 to 29 amps, depending upon the condition of the batteries and how much the batteries have been discharged.

Slight variations in the initial charge rate may also result from AC input line voltages which are higher or lower than 115 volts. Higher line voltages increase the initial charge rate while lower line voltages reduce the charge rate.

If the batteries are heavily discharged and the AC input line voltage is higher than 115 volts, the initial charge rate may exceed 30 amps and the ammeter needle will be pegged at 30 amps. Under normal conditions, the charge rate will taper to less than 30 amps within 30 minutes. If the ammeter still reads 30 amps after 30 minutes, turn the charger off by disconnecting the power supply cord from its outlet. Refer to the Troubleshooting Guide in this manual for additional information.

⚠ CAUTION: TO PREVENT OVERHEATING DAMAGE TO THE CHARGER, DO NOT ALLOW THE CHARGER TO OPERATE FOR MORE THAN 30 MINUTES WITH THE AMMETER READING 30 AMPS.

During charge, the battery voltage increases gradually, which causes the charge rate to decrease. Good battery cells should each rise

to approximately 2.5 volts DC, which will allow the charge rate to taper to less than 8 amps. Since each cell accepts charge at a slightly different rate, normal charging with the ammeter reading in the 4 to 10 amps area for the last few hours of charge is important to achieve equalization of all battery cells every time the batteries are charged.

The charger turns off automatically when the batteries are fully charged. The required charge time varies with battery size and depth of discharge. Allow sufficient time, as listed in the following chart, for normal charging.

Battery Capacity (Ampere Hours @ 20 Hr. Rate)	Normal Charge Time (Hours)
180	9
190	10
220	11
230	12

The normal charge times listed above are for batteries which have been discharged to 80% of their rated capacity. As much as 4 ADDITIONAL HOURS may be required to properly charge batteries under the following conditions:

- Heavily discharged batteries (more than 80% discharged)
- Charging new batteries (batteries with less than 50 discharge/charge cycles)
- Charging cold batteries (ambient temperatures below 65°F)

When charging new or cold batteries, a higher than normal finish charge voltage can be expected. This results in a low finish charge rate (4-6 amps), and additional time is required to achieve equalization of all battery cells. Refer to a qualified service agent if the charger does not turn off within the specified time.

⚠ WARNING: DO NOT LEAVE THE CHARGER UNATTENDED FOR MORE THAN TWO DAYS IN A ROW. SEVERE OVERCHARGING AND POSSIBLE DAMAGE TO THE BATTERIES WILL RESULT IF THE CHARGER SHOULD FAIL TO TURN OFF.

As batteries age, individual cells may weaken resulting in a lower than normal finish charge voltage. As the finish charge voltage decreases, the charge rate will not taper into the 5-10 amps area on the ammeter. The electronic timer will, however, still determine when the batteries have reached full charge and turn the charger off. Even though they are properly charged, older batteries will gradually lose capacity, and should

be replaced when they will no longer perform as required.

4. After the charger has turned off, disconnect the charger DC output plug from the battery receptacle by grasping the plug body or handle and pulling the plug straight out of the receptacle.

⚠ WARNING: TO AVOID DAMAGE TO THE CHARGER CORD, PLUG, AND BATTERY RECEPTACLE, DO NOT PULL ON THE CHARGER CORD. DO NOT TWIST, ROCK, OR PULL THE PLUG SIDEWAYS.

BATTERY STORAGE MAINTENANCE

When the machine is not in use, charge the batteries once each week. Disconnect the charger DC output cord at the end of the charge.

PROPER CARE OF MOTIVE POWER BATTERIES

Motive power batteries are subjected to severe deep cycle duty on a daily basis. Although these batteries are designed to withstand such duty, the following precautions must be observed to obtain good performance and maximum cycle life.

⚠ CAUTION: ALWAYS WEAR PROTECTIVE CLOTHING AND EYE SHIELDS WHEN WORKING WITH BATTERIES. BATTERIES CONTAIN ACIDS WHICH CAN CAUSE BODILY HARM. DO NOT PUT WRENCHES OR OTHER METAL OBJECTS ACROSS THE BATTERY TERMINAL OR BATTERY TOP. ARCING OR EXPLOSION OF THE BATTERY CAN RESULT.

1. When installing new batteries, be sure the polarity of each battery and overall battery pack is correct. Due to the electrical characteristics of this charger, it is possible to improperly hook up the batteries and not blow the fuse when charging. Battery and/or charger damage can result.
2. New batteries should be given a full charge before their first use because it is difficult to know how long the batteries have been stored.
3. Limit the use of new batteries for the first five cycles. New batteries and older batteries that have been in storage are not capable of their rated output until they have been discharged and charged a number of times.
4. Sulfation results when batteries in storage are not maintained in a charged active state. Internal self-discharge can bring about the start of this condition in as little as three days in warm temperatures. Batteries allowed to sit unmaintained in storage self-discharge, sulfate to various degrees, and lose capacity. Repeated charging will generally result in the recovery of

most of the battery's capacity, though some permanent loss can be expected.

5. Do not excessively discharge the batteries. Excessive discharge can cause polarity reversal of individual cells, resulting in complete failure shortly thereafter. Limited use of new batteries will minimize the risk of cell reversals.
6. Maintain the proper electrolyte level by adding water when necessary. Never allow the electrolyte level to fall below the top of the battery plates. Electrolyte levels fall during discharge and rise during charge. Therefore, to prevent the overflow of electrolyte when charging, it is mandatory that water be added to cells AFTER they have been fully charged; do not overfill. Old batteries require more frequent additions of water than do new batteries.
7. When the temperature falls below 65°F, the batteries should be placed on charge as soon after use as possible. Cold batteries require more time to fully recharge.
8. The tops of the batteries and battery hold-downs must be kept clean and dry at all times to prevent excessive self-discharge and flow of current between the battery posts and frame.
9. Follow all operating instructions, cautions, and warnings as specified in this manual, on the charger, and your vehicle owner manual.

TROUBLESHOOTING GUIDE

To be able to use the troubleshooting guide safely and effectively, it is important to read this guide completely before beginning any tests.

⚠ CAUTION: DO NOT DISASSEMBLE THE CHARGER. TAKE IT TO A QUALIFIED SERVICE AGENT WHEN SERVICE OR REPAIR IS REQUIRED. INCORRECT REASSEMBLY MAY RESULT IN A RISK OF ELECTRIC SHOCK OR FIRE.

The following procedures are intended only to determine if a malfunction may exist in the charger.

⚠ DANGER: TO REDUCE THE RISK OF ELECTRIC SHOCK, ALWAYS DISCONNECT BOTH THE POWER SUPPLY CORD AND THE OUTPUT CORD BEFORE ATTEMPTING ANY MAINTENANCE OR CLEANING.

⚠ WARNING: DO NOT OPERATE THE CHARGER IF IT IS MALFUNCTIONING. PERSONAL INJURY OR PROPERTY DAMAGE COULD RESULT.

To determine if a charger malfunction exists, identify the problem from the following list and refer to the appropriate section for detailed instructions.

1. CHARGER DOES NOT TURN ON
2. CHARGER FUSE BLOWS
3. THE AMMETER NEEDLE REMAINS AT 30 AMPS FOR MORE THAN ONE-HALF (½) HOUR
4. CHARGER DOES NOT TURN OFF
5. AC LINE FUSE OR CIRCUIT BREAKER BLOWS

If the problem is other than listed above, refer to a qualified service agent for additional troubleshooting procedures.

1. Charger does not turn on

The DC plug must be disconnected and reconnected to start the charger after turn-off.

Connect the power supply cord securely to a live AC outlet. Visually inspect the DC output plug and battery receptacle to be sure they are in good working condition.

⚠ WARNING: IF THE PLUG OR RECEPTACLE IS BROKEN, TWISTED, BENT OR LOOSE AND DOES NOT MAKE GOOD ELECTRICAL CONTACT, HAVE IT REPLACED BY A QUALIFIED SERVICE AGENT IMMEDIATELY. DO NOT USE THIS CHARGER IN THIS CONDITION AS FIRE OR PERSONAL INJURY CAN RESULT.

If the plug and receptacle are good, connect the DC plug into the receptacle and listen for the power relay inside the charger to "click" on within 5 seconds. If the "click" is not heard, remove the DC plug from the receptacle and connect the DC plug of another charger, which you know is operating properly, to the receptacle.

If still no "click" is heard, a malfunction in the batteries or receptacle wiring exists. If the "click" is heard, the batteries and receptacle are good, and a malfunction exists in the original charger.

If the relay "click" is heard, a hum from the transformer should be heard and the ammeter should indicate the charge rate. If no transformer hum is heard, check to be sure the AC power supply cord is securely connected to a live AC outlet. When three-prong to two-prong adapters are used, they tend to work loose, resulting in a poor connection. Check the AC line fuse or circuit breaker and, if possible, connect a functioning charger, utility light, or other electrical appliance to the outlet to verify the presence of AC power. If AC power is present, and still no transformer hum is heard, the charger is malfunctioning. If the relay "clicks" and the transformer hums, but no charge rate is indicated on the ammeter, the charger is malfunctioning.

2. Charger fuse blows

The charger fuse assembly consists of a double-ended fuse wire visible through a transparent cover mounted on the front panel. Each half of the fuse wire serves as an individual fuse link which protects the charger in the event one or both rectifier diodes fail, or a reverse polarity connection is made to the batteries.

Check the fuse assembly visually for an open or blown fuse link. If both half links of the fuse assembly blow as soon as the DC output plug is connected to the battery receptacle, the polarity of the batteries may be reversed. If no battery or receptacle maintenance has been performed prior to the fuse blowing, the charger is malfunctioning. If only one half link blows, the charge rate will be low and the charger is malfunctioning.

⚠ CAUTION: DO NOT USE THE CHARGER IF THE OUTPUT IS LOW. BATTERIES WILL NOT REACH FULL CHARGE, THEREBY INCREASING THE POSSIBILITY OF A HARMFUL DEEP DISCHARGE DURING THEIR NEXT USE.

3. Ammeter needle remains at 30 amps for more than one-half (½) hour

This condition normally results if the charger is connected to a battery system which is less than 36 volts. If connected to a 12-, 18-, 24-, or 30-volt battery system, the charge rate will not taper below 30 amps within 30 minutes. This may also result if a 36-volt battery system is wired incorrectly or if the battery polarity markings are reversed. Have a qualified service agent check the wiring of the batteries and the charging receptacle.

⚠ CAUTION: DO NOT CONNECT THE CHARGER TO BATTERY PACKS WHICH ARE NOT 36-VOLT SYSTEMS. OVERHEATING AND TRANSFORMER BURN-OUT WILL RESULT.

4. Charger does not turn off

New batteries or batteries charged in cold temperatures may require an extended charge time to achieve full charge. However, if the charger runs for more than 18 hours without shutting off, the charger is malfunctioning.

5. AC line fuse or circuit breaker blows

If this occurs, the charger may be malfunctioning or the AC line fuse/circuit breaker may be "weak". Connect another charger, which you know is operating properly, to the same AC outlet. If the fuse/circuit breaker still blows, have a qualified electrician check for a "weak" line fuse/circuit breaker. If the line fuse/circuit breaker works properly with the second charger, the original charger is malfunctioning.

WIRING DIAGRAM

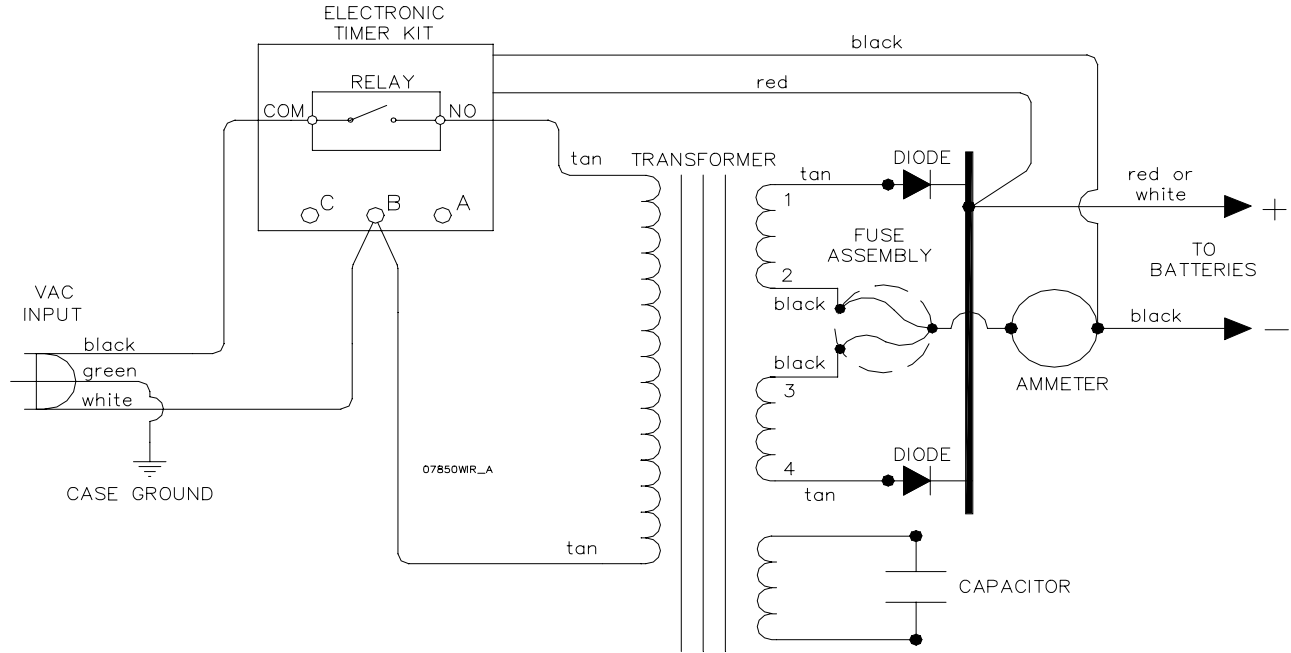

PARTS LIST FOR LESTRONIC II CHARGER MODEL 07850 TYPE 36LC25-8ET 105-128 VAC / 60 HZ

PART NO.	DESCRIPTION
07684S	CASE ASSEMBLY
09691S	TRANSFORMER ASSEMBLY
02390S	CAPACITOR, 6 MFD, 660 VAC
16354S	HEATSINK ASSEMBLY W/ DIODES
08776S	FUSE ASSEMBLY, DC OUTPUT
16369S	AMMETER, 0-30 AMP
24925S	ELECTRONIC TIMER KIT
* 04484S	RELAY, FOR ELECTRONIC TIMER
** 23385S	RELAY, FOR ELECTRONIC TIMER
02028S	BUSHING, 7W-2, FOR CORDSETS
02506S	AC CORDSET, 6 FT.
02106S	AC CORDSET, 9 FT.
08512S	DC CORDSET, 12/2, 108", NO PLUG
14973S	DC CORDSET, 12/2, 108", GRAY SILICONE PLUG
18772S	DC CORDSET, 10/2, 144", GRAY SILICONE PLUG
18773S	DC CORDSET, 10/2, 250", GRAY SILICONE PLUG
08020S	DC CORDSET, 12/2, 108", LESTER YELLOW PLUG
08607S	DC CORDSET, 12/2, 108", W/ SB50 PLUG, GRAY
10536S	DC CORDSET, 12/2, 130", W/ SB175 PLUG, GRAY
08313S	PLUG ASSEMBLY, SB50, GRAY
02957S	PLUG ASSEMBLY, SB175, GRAY
08045S	DC RECEPTACLE ASSEMBLY, FOR MOLDED RUBBER OR LESTER YELLOW PLUG
09445K	TEST AND INSPECTION KIT FOR 08045S RECEPTACLE
00910	OPERATION AND REPAIR MANUAL FOR MODEL 07850

* FOR USE WITH CHARGERS BUILT BEFORE 09/04

** FOR USE WITH CHARGERS BUILT AFTER 09/04

⚠ WARNING: ALL ELECTRICAL REPAIRS MUST BE PERFORMED BY QUALIFIED PERSONNEL ONLY. INCORRECT REASSEMBLY MAY RESULT IN A RISK OF ELECTRIC SHOCK OR FIRE.

LIMITED WARRANTY

Lester Electrical warrants each new Lester Battery Charger for defects in material and workmanship for a period of two (2) years from the date of manufacture of the complete unit. Repairs can be made at the Lester factory. To do so, first obtain a "Return Material Authorization" number by calling the Service Department of Lester Electrical (402 477-8988) or by e-mailing service@lesterelectrical.com and send the defective unit with transportation charges prepaid to:

Lester Electrical
625 West A Street
Lincoln, NE 68522-1794 USA
Attention: Service Department
RMA # _____

For repairs made at other than the Lester factory, Lester will provide only the replacement parts. Defective parts should be sent with transportation charges prepaid to the Lester factory at the address noted above.

If the unit or parts are found in the reasonable judgment of Lester to be defective in material or workmanship, repair or replacement will be made by Lester without charge for parts or labor. Repair or replacement will be at the discretion of Lester, with replacements being made using current models or parts performing the equivalent function. Labor charges other than those incurred at the Lester factory are not covered under this warranty. All expenses associated with delivering defective items to the Lester factory and the expense of returning repaired or replaced items from the Lester factory to the owner will be paid for by the owner. All warranty work accomplished at the Lester factory will be completed with a reasonable time after receipt of defective items.

This warranty does not cover any semiconductor parts, such as diodes, which are vulnerable to electrical overloads beyond the control of Lester. Warranty on parts not manufactured by Lester, which include, but are not limited to, timers and ammeters, is limited to the period specified in the original manufacturer's warranty.

This warranty does not cover any charger that has been subject to misuse, neglect, negligence, or accident, or operated in any way contrary to instructions specified on the charger case and in the owner's manual. No claim of breach of warranty shall be cause for cancellation of the contract of sale of any Lester charger. Lester assumes no responsibility for loss of time, inconvenience, or other damage, consequential or otherwise, resulting from a defective charger. All implied warranties (including merchantability) are limited in duration to the two years from date of manufacture warranty period.

Some states do not allow the exclusion or limitation of incidental or consequential damages; or limitations on how long an implied warranty lasts, so the above limitations may not apply to you. This warranty gives you specific legal rights, and you may also have other rights which vary from state to state.

Lester's obligation under this warranty is strictly and exclusively limited to the repair or replacement of defective items. Lester issues this warranty in good faith and with full confidence in the workmanship and quality of Lester products.