



LESTRONIC II 48 VOLT AUTOMATIC BATTERY CHARGER

MODEL 18740 TYPE 48LC25-8ET

Specifications	
AC Input:	100-125 or 200-250 volts, 16 or 8 amps, 60 Hertz, single-phase
DC Output:	48 volts, 25 amps, tapering to 8 amps
Battery Specifications:	For use with 48 volt, 24 cell, series connected, 180-350 amp-hour, liquid electrolyte (wet) lead-acid batteries

PLEASE SAVE THESE IMPORTANT SAFETY AND OPERATING INSTRUCTIONS

For correct operation of the equipment, it is important to read and be familiar with this entire manual before installing and operating the charger.
DO NOT DISCARD THIS MANUAL AFTER READING.



LOOK FOR THIS SYMBOL TO POINT OUT SAFETY PRECAUTIONS. IT MEANS: BECOME ALERT—YOUR SAFETY IS INVOLVED. IF YOU DO NOT FOLLOW THESE SAFETY INSTRUCTIONS, INJURY OR PROPERTY DAMAGE CAN OCCUR.

IMPORTANT SAFETY INSTRUCTIONS

1. This manual contains important safety and operating instructions for battery charger Model 18740.
2. Before using battery charger, read all instructions and cautionary markings on battery charger, battery, and product using battery.
3. Do not expose charger to rain or snow.
4. Use of an attachment not recommended or sold by the battery charger manufacturer may result in risk of fire, electric shock, or injury to persons.
5. To reduce risk of damage to electric plug and cord, pull by plug rather than cord when disconnecting charger.
6. Make sure cord is located so that it will not be stepped on, tripped over, or otherwise subjected to damage or stress.
7. When using an extension cord, make sure that:
 - a. Pins on plug of extension cord are the same number, size, and shape as those of plug on charger.
 - b. Extension cord is properly wired and in good electrical condition.
 - c. Wire size is large enough for AC ampere rating of charger.
8. Do not operate charger with damaged cord or plug; replace it immediately.
9. Do not operate charger if it has received a sharp blow, been dropped, or otherwise damaged in any way; take it to a qualified service center.
10. Do not disassemble charger; take it to a qualified service center when service or repair is required. Incorrect reassembly may result in a risk of electric shock or fire.
11. To reduce risk of electric shock, unplug charger from a live outlet or disconnect AC power to the outlet before attempting any maintenance or

cleaning. Turning off controls will not reduce this risk.

INTRODUCTION

The battery charger is a self-regulating charger with a minimum of moving parts, designed for long, trouble-free service. Built-in line voltage compensation produces a consistent output when the AC supply voltage varies by as much as 10% from nominal. Convection cooling maximizes the reliability and minimizes any maintenance costs. ONLY LIQUID ELECTROLYTE (WET) LEAD ACID BATTERIES should be recharged with this charger to ensure superior battery performance and life. A patented electronic circuit turns the charger on and off automatically. When the battery has reached its maximum state of charge, the circuitry will turn the charger off.

RECEIVING AND INSTALLING THE CHARGER

When the charger is received, check for possible in-transit damage. If any damage is found, it should be reported as a claim to the carrier.

Proper installation of the charger is important in order to achieve good charger performance and to prevent damage to the charger and batteries. The charger should be located in a clean, cool, dry, and well ventilated area. To permit free air flow for convection cooling, allow three inches (3") minimum between the charger and any wall.

⚠ DANGER: TO REDUCE THE RISK OF FIRE, DO NOT USE THE CHARGER NEAR FLAMMABLE MATERIALS OR VAPORS.

AC INPUT

⚠ CAUTION: TO REDUCE RISK OF ELECTRIC SHOCK OR FIRE, DISCONNECT POWER FROM AC RECEPTACLE BEFORE INSTALLING, CHANGING AC VOLTAGE, OR REMOVING UNIT.

This charger can be adjusted to operate on two different 60 Hertz, single-phase AC line voltages. Remove the cover to determine or change the internal line voltage setting. Refer to wiring diagram at the end of these instructions.

NOTE: Transformer primary lead #5 remains connected to timer kit terminal #2 and transformer primary lead #8 remains connected to timer kit terminal #3 for either voltage setting.

For 100-125 VAC: Connect transformer primary lead #6 to timer kit terminal #3, AND transformer primary lead #7 to timer kit terminal #2.

For 200-250 VAC: Connect BOTH transformer primary leads #6 and #7 to timer kit terminal #6.

GROUNDING INSTRUCTIONS

This battery charger must be grounded to reduce risk of electric shock. This charger is equipped with an AC supply cord having an equipment-grounding conductor which must be connected to the ground prong of an appropriate plug for the AC voltage being used. This plug must be connected to an appropriate AC outlet which is properly installed and grounded in accordance with the National Electrical Code (U.S.) and all local codes and ordinances.

⚠ DANGER: IMPROPER CONNECTION OF THE EQUIPMENT-GROUNDING CONDUCTOR CAN RESULT IN A RISK OF ELECTRIC SHOCK.

The conductor with insulation having an outer surface which is green, with or without yellow stripe(s), is the equipment-grounding conductor. If repair or replacement of the AC supply cord or plug is necessary, do not connect the equipment-grounding conductor to a live terminal. Refer to a qualified service agent.

EXTENSION CORD REQUIREMENTS

Always use a three-conductor, No. 14 AWG (1.5mm) heavy duty cord with ground, properly wired, in good electrical condition and keep it as short as possible. Make sure the pins on the plug of the extension cord are the same number, size and shape as the AC plug of the battery charger. The use of an improper extension cord could result in a risk of fire or electric shock. Locate all cords so they will not be stepped on, tripped over or otherwise subjected to damage or stress.

DC OUTPUT

This battery charger is designed to produce a 48-volt DC output with an initial charge current of 25 amps. ONLY 48 VOLT, 24 CELL, SERIES CONNECTED, 180 TO 350 AMP-HOUR, LIQUID-ELECTROLYTE (WET) LEAD-ACID BATTERIES SHOULD BE USED. The charge current will decrease gradually to about 8 amps as the battery reaches full charge and will remain there until the charger turns off. As the battery ages, the charge current may no longer decrease to the 8-amp finish current. Liquid electrolyte batteries will normally be charged to 2.5-2.6 volts per cell.

OPERATING INSTRUCTIONS

1. Connect the DC output cable to the batteries. The BLACK wire must be connected to battery negative (-), and the RED or WHITE wire to battery positive (+). Make sure all connections are clean and tight.
2. Connect AC supply cord to a properly grounded 100-125 or 200-250 VAC, 60 Hertz, single

phase outlet. Make sure charger is set to operate on the AC voltage being used. See AC Input and Grounding sections of this manual.

3. The charger will start after a short delay as indicated by the ammeter and transformer hum.

⚠ WARNING: LEAD ACID BATTERIES GENERATE GASES WHICH CAN BE EXPLOSIVE. CHARGE ONLY IN WELL VENTILATED AREAS. DO NOT DISCONNECT CHARGER DC OUTPUT TERMINALS FROM BATTERY WHEN CHARGER IS ON. THE RESULTING ARCING AND BURNING COULD CAUSE THE BATTERY TO EXPLODE. KEEP SPARKS, FLAME, AND SMOKING MATERIALS AWAY FROM BATTERY.

If the charger must be stopped, always disconnect the AC supply cord from its outlet before disconnecting the DC output terminals from the battery.

4. The initial charge current should range between approximately 20 to 29 amps. If the batteries have not been discharged, or the AC supply voltage is lower than the nominal AC voltage being used, the initial charge rate may be less. If the batteries have been excessively discharged, or AC supply voltage is higher than the nominal AC voltage being used, the initial charge rate may be more.
5. Charge current will gradually taper to approximately 8 amps depending on the age and condition of the batteries. Charger turns off automatically when battery is fully charged. Charge time varies with battery size and depth of discharge. Allow 11-15 hours for normal charging. Severely discharged batteries may require more time to be properly charged and equalized.
6. After the charger has turned off, disconnect the AC supply cord from outlet.

MAINTENANCE INSTRUCTIONS

The battery charger requires minimal maintenance. It should be kept clean and all connections are to be tightly secured. In the event of intermittent operation, examine and tighten, if necessary, all connections. **BE SURE THE CHASSIS IS SECURELY GROUNDED.** If any problems cannot be resolved, consult a qualified service center.

Observe the following battery maintenance procedures to obtain good performance and maximum cycle life.

1. Always observe the following personal safety precautions when working with lead acid batteries:

- a. Someone should be within range of your voice or close enough to come to your aid when you work near a battery.
- b. Have plenty of fresh water and soap nearby in case battery acid contacts skin, clothing or eyes.
- c. Wear complete eye and clothing protection. Avoid touching eyes while working near battery.
- d. If battery acid contacts skin or clothing, wash immediately with soap and water. If acid enters eye, immediately flood eye with running cold water for at least 10 minutes and get medical attention.
- e. NEVER smoke or allow a spark or flame in the vicinity of batteries.
- f. Be extra cautious to reduce risk of dropping a metal tool onto battery. It might spark or short-circuit battery or other electrical part that may cause explosion.
- g. Remove personal metal items such as rings, bracelets, necklaces, and watches when working with a lead acid battery. A lead acid battery can produce a short-circuit current high enough to weld a ring or the like to metal, causing a severe burn.
- h. NEVER charge a frozen battery.

⚠ DANGER: TO REDUCE RISK OF ELECTRIC SHOCK, ALWAYS DISCONNECT THE AC SUPPLY CORD FROM ITS OUTLET AND THE DC OUTPUT CORD FROM THE BATTERY BEFORE ATTEMPTING ANY MAINTENANCE (CHANGING FUSES, ETC.) OR CLEANING OF THE BATTERY OR BATTERY CHARGER.

2. New batteries should be given a full charge before their first use because it is difficult to know how long batteries have been stored.
3. Limit use of new batteries for first five cycles. New batteries are not capable of their rated output until they have been discharged a number of times.
4. Do not excessively discharge batteries. Excessive discharge can cause polarity reversal of individual cells resulting in complete failure shortly thereafter. Limited use of new batteries will minimize the chance of cell reversal.
5. CHECK THE LEVEL OF THE ELECTROLYTE IN CONVENTIONAL LIQUID ELECTROLYTE LEAD ACID BATTERIES MONTHLY. MAINTAIN THE PROPER ELECTROLYTE LEVEL BY ADDING DISTILLED OR PURIFIED WATER WHEN NECESSARY. Electrolyte levels lower during discharge and rise during charge. Therefore, it is mandatory that water be added to cells ONLY when they are fully

charged; do not overfill. Old batteries require more frequent additions of water than new batteries.

6. Keep tops of batteries clean and dry to prevent excessive self-discharge. Keep battery terminals reasonably tight.

TROUBLESHOOTING GUIDE

For safe and efficient troubleshooting, read this guide completely before beginning any tests.

⚠ CAUTION: DO NOT OPERATE THE CHARGER IF IT IS DAMAGED OR APPEARS TO BE MALFUNCTIONING. PERSONAL INJURY OR DAMAGE TO THE CHARGER OR BATTERIES MAY RESULT. DO NOT DISASSEMBLE THE CHARGER. TAKE IT TO A QUALIFIED SERVICE AGENT WHEN SERVICE OR REPAIR IS REQUIRED. INCORRECT REASSEMBLY MAY RESULT IN RISK OF ELECTRIC SHOCK OR FIRE.

To determine if a charger malfunction exists, eliminate the problems not associated with the charger in the sections below. If the problem cannot be resolved, contact a qualified service center.

1. CHARGER DOES NOT TURN ON

- a. Battery is not connected to charger.
- b. Charger is not plugged into a live AC outlet.
- c. DC fuses blown.

⚠ WARNING: IF THE AC OR DC PLUG OR RECEPTACLE IS BROKEN, TWISTED, BENT OR LOOSE AND DOES NOT MAKE GOOD ELECTRICAL CONTACT, HAVE IT REPLACED BY QUALIFIED SERVICE PERSONNEL IMMEDIATELY. DO NOT USE THIS CHARGER IN THIS CONDITION AS FIRE OR PERSONAL INJURY CAN RESULT.

2. CHARGER REMAINS AT HIGH RATE

- a. The charger is connected to a battery pack with a system voltage lower than specified.
- b. Battery amp-hour capacity is greater than specified for charger.
- c. One or more of the batteries in the battery pack has reversed polarity.

3. CHARGER TURNS OFF EARLY

- a. The DC cord was accidentally disconnected from the battery during charge.
- b. The battery has been allowed to sulfate. Charge the battery at least once every three days when the equipment is lightly utilized.

Once sulfation is allowed to take place, it may be partially reduced by returning, temporarily, to daily charging.

- c. AC circuit is not live (power outage or circuit breaker blown).

4. CHARGER DOES NOT TURN OFF

- a. The charger is connected to a battery with an amp-hour capacity greater than specified.
- b. The charger is connected to a battery pack with a system voltage higher or lower than specified.
- c. New batteries (5 cycles or less), cold batteries or overdischarged batteries may require an extended charge time to achieve full charge.

5. CHARGER FUSE BLOWS (OR CIRCUIT BREAKER)

- a. AC fuse blows when wrong AC power supply is used.

6. BUILDING AC LINE CIRCUIT BREAKER OR FUSE BLOWS

- a. A "weak" fuse or circuit breaker is protecting the circuit. Connect the charger to another outlet on a different circuit. If the charger operates properly, have a qualified electrician inspect and test the original circuit.
- b. The circuit is overloaded. Connect the charger to another outlet on a different circuit.

7. EQUIPMENT RANGE DECREASING

- a. The electrolyte level in conventional liquid electrolyte lead-acid batteries was allowed to drop below the top of the battery plates. Add distilled water to just cover the tops of the plates immediately upon discovery and fill to the proper level with distilled water at the completion of the very next charge cycle. Battery capacity lost in this manner is permanent and is not recovered with additional charge cycles.
- b. Use of the equipment before the batteries have been fully charged and the charger turns off. This shortens battery life and hastens the onset of reduced daily range. Battery capacity lost in this manner is permanent and is not recovered with additional charge cycles.
- c. This is the normal wearout process for all types of deep-cycle motive power batteries.

WIRING DIAGRAM

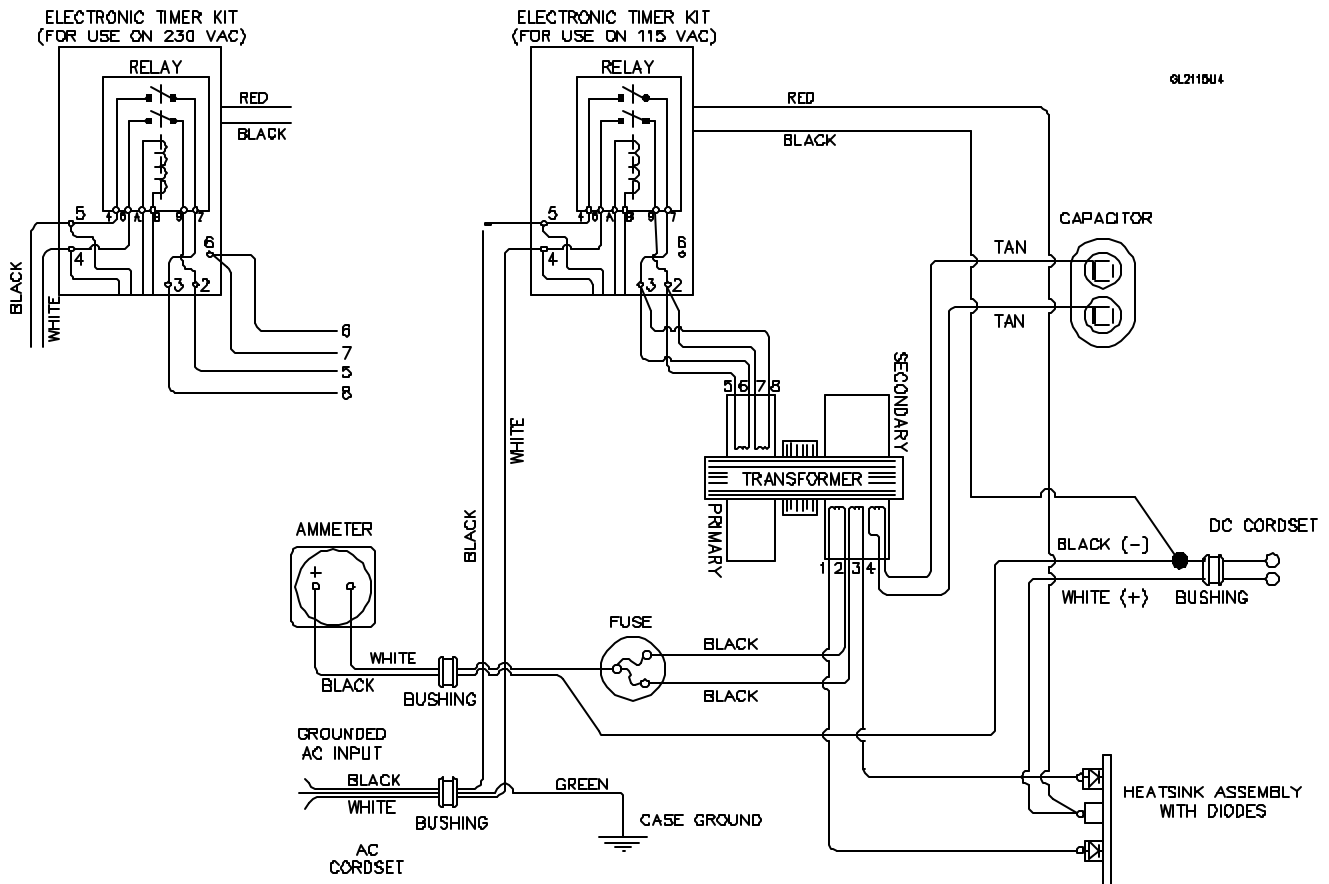

PARTS LIST FOR LESTRONIC II CHARGER MODEL 18740 TYPE 48LC25-8ET 100-125/200-250 VAC, 60 Hz

PART NO.	QTY.	DESCRIPTION
24999S	1	CASE ASSEMBLY
24998S	1	TRANSFORMER ASSEMBLY
16354S	1	HEATSINK ASSEMBLY, W/ DIODES
16369S	1	AMMETER
14930S	1	ELECTRONIC TIMER ASSEMBLY
02390S	1	CAPACITOR, 6.0 MFD, 660 VAC
08776S	1	FUSE ASSEMBLY
02028S	1	BUSHING, 7W-2, INSULATOR FOR AC CORD
02008S	2	BUSHING, 8P-2, INSULATOR FOR DC/AMMETER CORD
24364S	1	CORDSET, AC, 14/3, 46"
25787S	1	CORDSET, AC, 14/3, 94"
30764S	1	CORDSET, AC, 14/3, 40"
25788S	1	CORDSET, DC, 10/2, 3/8 RINGS, 54"
24436S	1	CORDSET, DC, 10/2, 3/8 RINGS, 74"
27652S	1	CORDSET, DC, 10/2, 3/8 RINGS, 85"
25786S	1	CABLE, REMOTE AMMETER, 10/2, 92"
24358S	1	CABLE, REMOTE AMMETER, 10/2, 26"
30763S	1	CABLE, REMOTE AMMETER, 10/2, 36"

LIMITED WARRANTY

Lester Electrical warrants each new Lester Battery Charger for defects in material and workmanship for a period of two (2) years from the date of manufacture of the complete unit. Repairs can be made at the Lester factory. To do so, first obtain a "Return Material Authorization" number by calling the Service Department of Lester Electrical (402 477-8988) or by e-mailing service@lesterelectrical.com and send the defective unit with transportation charges prepaid to:

Lester Electrical
625 West A Street
Lincoln, NE 68522-1794 USA
Attention: Service Department
RMA # _____

For repairs made at other than the Lester factory, Lester will provide only the replacement parts. Defective parts should be sent with transportation charges prepaid to the Lester factory at the address noted above.

If the unit or parts are found in the reasonable judgment of Lester to be defective in material or workmanship, repair or replacement will be made by Lester without charge for parts or labor. Repair or replacement will be at the discretion of Lester, with replacements being made using current models or parts performing the equivalent function. Labor charges other than those incurred at the Lester factory are not covered under this warranty. All expenses associated with delivering defective items to the Lester factory and the expense of returning repaired or replaced items from the Lester factory to the owner will be paid for by the owner. All warranty work accomplished at the Lester factory will be completed with a reasonable time after receipt of defective items.

This warranty does not cover any semiconductor parts, such as diodes, which are vulnerable to electrical overloads beyond the control of Lester. Warranty on parts not manufactured by Lester, which include, but are not limited to, timers and ammeters, is limited to the period specified in the original manufacturer's warranty.

This warranty does not cover any charger that has been subject to misuse, neglect, negligence, or accident, or operated in any way contrary to instructions specified on the charger case and in the owner's manual. No claim of breach of warranty shall be cause for cancellation of the contract of sale of any Lester charger. Lester assumes no responsibility for loss of time, inconvenience, or other damage, consequential or otherwise, resulting from a defective charger. All implied warranties (including merchantability) are limited in duration to the two years from date of manufacture warranty period.

Some states do not allow the exclusion or limitation of incidental or consequential damages; or limitations on how long an implied warranty lasts, so the above limitations may not apply to you. This warranty gives you specific legal rights, and you may also have other rights which vary from state to state.

Lester's obligation under this warranty is strictly and exclusively limited to the repair or replacement of defective items. Lester issues this warranty in good faith and with full confidence in the workmanship and quality of Lester products.