



LESTRONIC II BATTERY CHARGER

MODEL 19740

PLEASE SAVE THESE IMPORTANT SAFETY AND OPERATING INSTRUCTIONS

For correct operation of the equipment, it is important to read and be familiar with this entire manual before installing and operating the charger.
DO NOT DISCARD THIS MANUAL AFTER READING.



LOOK FOR THIS SYMBOL TO POINT OUT SAFETY PRECAUTIONS. IT MEANS: BECOME ALERT—YOUR SAFETY IS INVOLVED. IF YOU DO NOT FOLLOW THESE SAFETY INSTRUCTIONS, INJURY OR PROPERTY DAMAGE CAN OCCUR.

1. This manual contains important safety and operating instructions for your battery charger.
2. Before using battery charger, read all instructions and cautionary markings on battery charger, battery, and product using battery.
 - a. Pins on plug of extension cord are the same number, size, and shape as those of plug on charger.
 - b. Extension cord is properly wired and in good electrical condition.
 - c. Wire size is large enough for AC ampere rating of charger.
3. Do not expose charger to rain or snow.
4. Use of an attachment not recommended or sold by the battery charger manufacturer may result in a risk of fire, electric shock, or injury to persons.
5. To reduce risk of damage to electric plug and cord, pull by plug rather than cord when disconnecting charger.
6. Make sure cord is located so that it will not be stepped on, tripped over, or otherwise subjected to damage or stress.
7. An extension cord should not be used unless absolutely necessary. Use of improper extension cord could result in a risk of fire and electric shock. If extension cord must be used, make sure:
 8. Do not operate charger with damaged cord or plug; replace it immediately.
 9. Do not operate charger if it has received a sharp blow, been dropped, or otherwise damaged in any way; take it to a qualified service center.
 10. Do not disassemble charger; take it to a qualified service center when service or repair is required. Incorrect reassembly may result in a risk of electric shock or fire.
 11. To reduce risk of electric shock, unplug charger from a live outlet or disconnect AC power to the outlet before attempting any maintenance or cleaning. Turning off controls will not reduce this risk.

INTRODUCTION

This battery charger is a self-regulating charger with a minimum of moving parts, designed for long, trouble-free service. Built-in line voltage compensation produces a consistent output when the AC supply voltage varies by as much as 10% from

nominal. The charger utilizes convection cooling which maximizes the reliability and minimizes any maintenance costs. Only liquid electrolyte (wet) lead acid batteries should be recharged with this charger to ensure superior battery performance and life. A patented electronic circuit turns the charger on and off automatically. When the battery has reached its maximum state of charge, the circuitry will turn the charger off.

RECEIVING AND INSTALLING THE CHARGER

When the charger is received, portable chargers should be checked for possible in-transit damage. If any damage is found, it should be reported as a claim to the carrier.

Proper installation of the charger is important in order to achieve good charger performance and to prevent damage to the charger and batteries. The charger should be located in a clean, cool, dry and well-ventilated area. To permit free airflow for convection cooling, allow three inches (3") minimum between the charger and any wall and six inches (6") between the charger and other equipment. Position the charger on a foundation of stone, brick, concrete or grounded metal.

⚠ DANGER: TO REDUCE THE RISK OF FIRE, DO NOT USE THE CHARGER NEAR FLAMMABLE MATERIALS OR VAPORS.

AC INPUT AND GROUNDING INSTRUCTIONS

⚠ CAUTION: TO REDUCE THE RISK OF ELECTRIC SHOCK OR FIRE, DISCONNECT POWER TO RECEPTACLE BEFORE INSTALLING OR REMOVING UNIT.

For 120 VAC Nominal, 60 Hz Chargers:

Chargers should be grounded to reduce the risk of electric shock. Charger is equipped with an electric cord having an equipment-grounding conductor and a grounding plug. The installed plug must be plugged into an outlet that is properly installed and grounded in accordance with all electrical codes and ordinances.

⚠ DANGER: NEVER ALTER AC CORD OR PLUG PROVIDED IF IT WILL NOT FIT OUTLET. HAVE A PROPER OUTLET INSTALLED BY A QUALIFIED ELECTRICIAN. IMPROPER CONNECTION CAN RESULT IN A RISK OF ELECTRIC SHOCK.

This battery charger is for use on a nominal 120 volt circuit and has a grounding plug, which looks like the adapter illustrated in Figure A. A temporary adapter, which looks like the adapter illustrated in Figures B and C, may be used to connect this plug to a two-

pole receptacle as shown in Figure B if a properly grounded outlet is not available. The temporary adapter should be used only until a grounded outlet can be installed by a qualified electrician.

GROUNDING METHODS

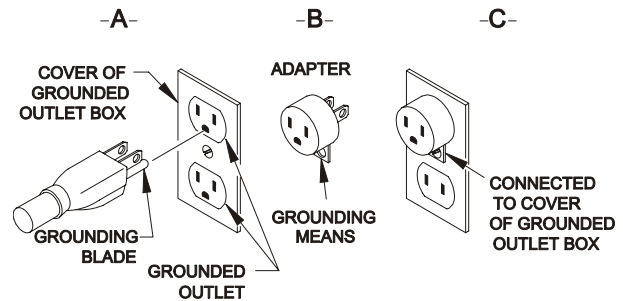

NOTE: The use of the adapter shown in figures B and C is not permitted in Canada.

⚠ DANGER: BEFORE USING ADAPTER AS ILLUSTRATED, BE CERTAIN THE CENTER SCREW OF OUTLET PANEL IS GROUNDED.

The green-colored rigid ear or lug extending from adapter must be connected to a properly grounded outlet. If necessary, replace original outlet cover plate screw with a longer screw that will secure adapter ear or lug to outlet plate and make ground connection to grounded outlet.

For 230 VAC Nominal, 50 Hz Chargers:

This battery charger must be grounded to reduce the risk of electric shock. This charger is equipped with an electrical cord having an equipment-grounding conductor, which must be connected to the ground prong of an appropriate plug for a nominal 230 Volt, 50 Hertz circuit. This plug must be connected to an appropriate AC outlet, which is properly installed and grounded in accordance with the National Electrical Code and all local codes and ordinances.

EXTENSION CORD REQUIREMENTS

Always use a three conductor No. 12 AWG heavy duty cord with ground, properly wired, in good electrical condition and keep it as short as possible. Make sure the pins on the plug of the extension cord are the same number, size and shape as the AC plug of the battery charger. The use of an improper extension cord could result in a risk of fire or electrical shock. Locate all cords so they will not be stepped on, tripped over or otherwise subjected to damage or stress.

OPERATING INSTRUCTIONS

1. Connect AC supply cord to a properly grounded single phase outlet of the proper voltage and frequency as specified on the charger front.

2. Connect the DC output plug, if not already connected, by grasping the plug body and pushing it straight into the receptacle until it is fully engaged. The BLACK wire must be connected to battery negative (-), and the RED or WHITE wire to battery positive (+). Make sure all connections are clean and tight.
3. The charger will start after a short delay as indicated by the transformer hum and the ammeter movement.

⚠ WARNING: LEAD ACID BATTERIES GENERATE GASES WHICH CAN BE EXPLOSIVE. CHARGE ONLY IN WELL VENTILATED AREAS. DO NOT DISCONNECT CHARGER DC OUTPUT TERMINALS FROM BATTERY WHEN CHARGER IS ON. THE RESULTING ARCING AND BURNING COULD CAUSE THE BATTERY TO EXPLODE. KEEP SPARKS, FLAME AND SMOKING MATERIALS AWAY FROM BATTERY.

If the charger must be stopped, always disconnect the AC cord from its outlet to terminate the charge.

4. Monitor the ammeter for correct charge rate. Normal charging at the finish charge rate for the last 3 to 5 hours is important to achieve equalization of all battery cells every time the batteries are charged. New batteries or batteries charged in cold temperatures (below 50°F) will require more time to achieve full charge.
5. Charger turns off automatically when battery is fully charged. Charge time varies with battery size and depth of discharge. Allow 8 hours for normal charging. Severely discharged batteries may require up to 12 hours to be properly charged and equalized. After the charger has turned off, disconnect the AC supply cord from outlet, then disconnect the DC output plug from the battery on portable chargers only.

⚠ CAUTION: DO NOT LEAVE CHARGER ON WHILE UNATTENDED FOR MORE THAN TWO CONSECUTIVE DAYS. SEVERE OVERCHARGING AND POSSIBLE DAMAGE TO BATTERIES WILL RESULT IF CHARGER SHOULD FAIL TO TURN OFF.

MAINTENANCE INSTRUCTIONS

The battery charger requires minimal maintenance. It should be kept clean and all connections are to be tightly secured. In the event of intermittent operation, examine and tighten, if necessary, all connections. Be sure the chassis is securely grounded. If any problems cannot be resolved, consult a qualified service center.

Observe the following battery cycle maintenance procedures to obtain good performance and maximum cycle life.

1. Always observe the following personal safety precautions when working with lead acid batteries:
 - a. Someone should be within range of your voice or close enough to come to your aid when you work near a battery.
 - b. Have plenty of fresh water and soap nearby in case battery acid contacts skin, clothing or eyes.
 - c. Wear complete eye protection and clothing protection. Avoid touching eyes while working near battery.
 - d. If battery acid contacts skin or clothing, wash immediately with soap and water. If acid enters eye, immediately flood eye with running cold water for at least ten minutes and get medical attention.
 - e. Never smoke or allow a spark or flame in the vicinity of batteries.
 - f. Be extra cautious to reduce risk of dropping a metal tool onto battery. It might spark or short-circuit battery or other electrical part that may cause explosion.
 - g. Remove personal metal items such as rings, bracelets, necklaces, and watches when working with a lead acid battery. A lead acid battery can produce a short-circuit current high enough to weld a ring or the like to metal, causing a severe burn.
 - h. Never charge a frozen battery.

⚠ DANGER: TO REDUCE RISK OF ELECTRIC SHOCK, ALWAYS DISCONNECT THE AC SUPPLY CORD FROM ITS OUTLET AND THE DC OUTPUT CORD FROM THE BATTERY BEFORE ATTEMPTING ANY MAINTENANCE (CHANGING FUSES, ETC.) OR CLEANING OF THE BATTERY CHARGER.

2. New batteries should be given a full charge before their first use because it is difficult to know how long batteries have been stored.
3. Limit use of new batteries for first five cycles. New batteries are not capable of their rated output until they have been discharged a number of times.
4. Do not excessively discharge batteries. Excessive discharge can cause polarity reversal of individual cells resulting in complete failure shortly thereafter. Limited use of new batteries will minimize the chance of cell reversal.

5. Check the level of the electrolyte in conventional liquid electrolyte lead acid batteries monthly. Maintain the proper electrolyte level by adding distilled or purified water when necessary. Electrolyte levels lower during discharge and rise during charge. Therefore, it is mandatory that water be added to cells only when they are fully charged; do not overfill. Old batteries

require more frequent additions of water than new batteries.

6. Keep tops of batteries clean and dry to prevent excessive self-discharge. Keep battery terminals reasonably tight.

WIRING DIAGRAM

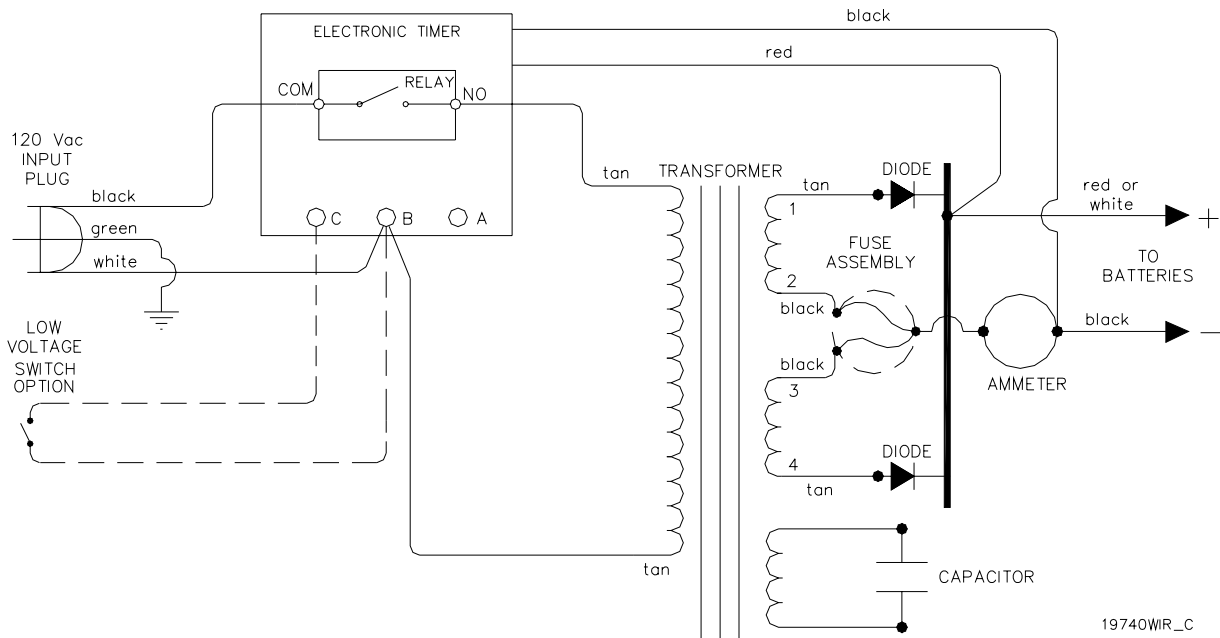

PARTS LIST FOR LESTRONIC II CHARGER, MODEL 19740, TYPE 24LC25-8ET, 120 VAC / 60 HZ

PART NO.	QTY.	DESCRIPTION	
31211S	1	CASE ASSEMBLY FOR DC W/ 2-#10 WIRES, (BASE WITH LOW VOLTAGE SWITCH)	
26838S	1	CASE ASSEMBLY FOR DC W/ 2-#10 WIRES	
27668S	1	CASE ASSEMBLY FOR DC W/ 1-10/2 CORD	
19745S	1	TRANSFORMER ASSEMBLY	
04401S	1	CAPACITOR, 4.0 MFD, 660 VAC	
16354S	1	HEATSINK ASSEMBLY W/ DIODES	
08776S	1	FUSE ASSEMBLY	
24800S	1	ELECTRONIC TIMER KIT	
*24228S	1	RELAY, FOR ELECTRONIC TIMER	
**23385S	1	RELAY, FOR ELECTRONIC TIMER	
16369S	1	AMMETER	
31086S	1	SWITCH, LOW VOLTAGE START	(-95 OPTION ONLY)
02028S	1	BUSHING, STRAIN RELIEF AC CORD	
27512S	1	BUSHING, KIT STRAIN RELIEF DC CORD	
07874S	1	CORDSET, AC, 14/3, SJT, 12", MOLDED PLUG	
25743S	1	CORDSET, DC, 2-#10, 45A POWERPOLE	(-91 OPTION)
27652S	1	CORDSET, DC, 10/2, SJO, NO PLUG	(-90 OPTION)
30443S	1	CORDSET, DC, 2-#10, SB50 RED PLUG	(-93 OPTION)
31051S	1	CORDSET, DC, 2-#10, 3/8" RINGS	(-95 OPTION)

* FOR USE WITH CHARGERS BUILT BEFORE 47/03

** FOR USE WITH CHARGERS BUILT AFTER 47/03

LIMITED WARRANTY

Lester Electrical warrants each new Lester Battery Charger for defects in material and workmanship for a period of two (2) years from the date of manufacture of the complete unit. Repairs can be made at the Lester factory. To do so, first obtain a "Return Material Authorization" number by calling the Service Department of Lester Electrical (402 477-8988) or by e-mail service@lesterelectrical.com and send the defective unit with transportation charges prepaid to:

Lester Electrical
625 West A Street
Lincoln, NE 68522-1794 USA
Attention: Repair Department
RMA# _____

For repairs made at other than the Lester factory, Lester will provide only the replacement parts. Defective parts should be sent with transportation charges prepaid to the Lester factory at the address noted above.

If the unit or parts are found in the reasonable judgment of Lester to be defective in material or workmanship, repair or replacement will be made by Lester without charge for parts or labor. Repair or replacement will be at the discretion of Lester, with replacements being made using current models or parts performing the equivalent function. Labor charges other than those incurred at the Lester factory are not covered under this warranty. All expenses associated with delivering defective items to the Lester factory and the expense of returning repaired or replaced items from the Lester factory to the owner will be paid for by the owner. All warranty work accomplished at the Lester factory will be completed with a reasonable time after receipt of defective items.

This warranty does not cover any semiconductor parts, such as diodes, which are vulnerable to electrical overloads beyond the control of Lester. Warranty on parts not manufactured by Lester, which include, but are not limited to, timers and ammeters, is limited to the period specified in the original manufacturer's warranty.

This warranty does not cover any charger that has been subject to misuse, neglect, negligence, or accident, or operated in any way contrary to instructions specified on the charger case and in the owner's manual. No claim of breach of warranty shall be cause for cancellation of the contract of sale of any Lester charger. Lester assumes no responsibility for loss of time, inconvenience, or other damage, consequential or otherwise, resulting from a defective charger. All implied warranties (including merchantability) are limited in duration to the two years from date of manufacture warranty period.

Some states do not allow the exclusion or limitation of incidental or consequential damages; or limitations on how long an implied warranty lasts, so the above limitations may not apply to you. This warranty gives you specific legal rights, and you may also have other rights which vary from state to state.

Lester's obligation under this warranty is strictly and exclusively limited to the repair or replacement of defective items. Lester issues this warranty in good faith and with full confidence in the workmanship and quality of Lester products.