

Lester

FULLY AUTOMATIC SCR BATTERY CHARGERS

FEATURES

- Microprocessor controlled charge circuit monitors battery state of charge and automatically turns charger off when the batteries reach full charge.
- Line voltage compensation produces consistent charger output for input voltage variations from nominal.
- Automatic taper of charge rate for superior battery life through optimum equalization of cells and low water use rate.
- Convection cooled design for maximum reliability and minimum maintenance.
- Factory set for either flooded or sealed batteries, but is field changeable.
- Battery maintenance feature keeps batteries charged while they are in storage.
- UL and CSA listed.

SPECIFICATIONS

Model	25910	25920	25900	25890	25930
AC volts	105 - 128	105 - 128	105 - 128	105 - 128	105 - 128
Frequency / Phase	60 / 1	60 / 1	60 / 1	60 / 1	60 / 1
AC Amps (Maximum)	8.5	9.5	11.5	13.5	11.5
Battery Pack Voltage	24 V	24 V	36 V	36 V	48 V
DC Output Current	21 Amps tapering to 6 Amps	25 Amps tapering to 8 Amps	21 Amps tapering to 6 Amps	25 Amps tapering to 8 Amps	17 Amps tapering to 6 Amps
Battery Capacity (20 hr. rate)	130 - 225	150 - 305	130 - 225	150 - 305	105 - 210
Size (H x W x L) / Weight	9" x 8.75" x 11" / 34 Lbs.	9" x 8.75" x 11" / 37 Lbs.	9" x 8.75" x 11" / 37 Lbs.	9" x 8.75" x 11" / 39 Lbs.	9" x 8.75" x 11" / 39 Lbs.

PLEASE SAVE THESE IMPORTANT SAFETY AND OPERATING INSTRUCTIONS

For correct operation of the equipment, it is important to read and be familiar with this entire manual before installing and operating the charger.
DO NOT DISCARD THIS MANUAL AFTER READING.



LOOK FOR THIS SYMBOL TO POINT OUT SAFETY PRECAUTIONS. IT MEANS: BECOME ALERT—YOUR SAFETY IS INVOLVED. IF YOU DO NOT FOLLOW THESE SAFETY INSTRUCTIONS, INJURY OR PROPERTY DAMAGE CAN OCCUR.

IMPORTANT SAFETY INSTRUCTIONS

Before using battery charger, read all instructions and cautionary markings on battery charger, battery and equipment. Use of an attachment not recommended or sold by battery charger manufacturer may result in a risk of fire, electric shock, or injury to persons.

INTRODUCTION

This battery charger is designed to recharge deep-cycle batteries of flooded or valve regulated design. A patented electronic circuit turns the charger on and off automatically.

Batteries used on industrial equipment are subjected to severe deep-cycle duty on a daily basis. For this reason, it is important that only deep-cycle batteries be used.

⚠ CAUTION: THIS CHARGER IS FOR USE ONLY ON RECHARGEABLE DEEP-CYCLE BATTERY SYSTEMS. THE FLOODED REPLACEABLE ELECTROLYTE DEEP-CYCLE BATTERY SETTING HAS AN ON-CHARGE VOLTAGE OF AT LEAST 2.50 VOLTS PER CELL. THE VALVE REGULATED GEL CELL OR SEALED DEEP-CYCLE BATTERY SETTING CHARGES TO A MAXIMUM ON-CHARGE VOLTAGE OF 2.38 VOLTS PER CELL. BATTERIES IMPROPERLY MATCHED WITH CHARGER MAY BURST CAUSING PERSONAL INJURY AND DAMAGE TO BATTERIES OR CHARGER.

Battery manufacturers frequently use the same battery cases for different battery types. Replaceable liquid electrolyte deep-cycle batteries have removable cell caps. Water electrolyzed by discharging and charging the battery is replaced through these openings.

Valve regulated gel cell or sealed "maintenance-free" deep-cycle batteries are generally distinguished by non-removable cell caps. The physical appearance of the battery case is frequently the same as a replacement liquid electrolyte battery, though the cell caps are generally not removable.

Refer to the battery manufacturer's information panel on the battery case to determine the type battery you have. If the information panel is missing or not legible, do not use the battery.

The charger is shipped to charge either flooded (replaceable liquid electrolyte) or valve regulated (gel or sealed maintenance free) lead-acid batteries as marked on the front of the charger. An internal jumper on the electronic controller may be adjusted to select which type of battery to charge. Remove the cover and position the jumper as shown in the

following figure. If changed from the factory setting, place a decal on the front of the charger over the existing marking "SET FOR XXX BATTERIES" to indicate the type of batteries to charge.

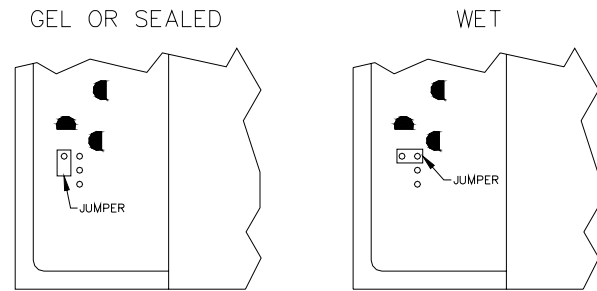

INITIAL INSTALLATION

Circuit breaker or fuse protection in the 120 volt AC outlet to which the charger is to be plugged should allow 15 amps per charger. Do not overload electrical outlet. Use of an extension cord with the charger should be avoided. Use of an improper extension cord could result in a risk of a fire and electric shock. If an extension cord is needed, use a three-conductor, No. 14 AWG (or larger) cord with ground, properly wired, in good electrical condition and keep as short as possible. Make sure that the pins on the plug of the extension cord are the same number, size, and shape as that of the plug on the battery charger. Locate all cords so that they will not be stepped on, tripped over, or otherwise subjected to damage or stress. Do not operate the battery charger with a damaged cord or plug. Do not operate the battery charger if it has received a sharp blow, was dropped or otherwise damaged in any manner. Refer to a qualified service agent.

Provide adequate ventilation for both batteries and charger. The convection cooled design requires an unobstructed flow of cooling air for proper operation. Keep all charger ventilation openings at least two inches (2") (5.08cm) away from walls and other objects. Do not allow clothing, blankets, or other material to cover charger.

⚠ WARNING: CHARGERS CAN IGNITE FLAMMABLE MATERIALS AND VAPORS. DO NOT USE NEAR FUELS, GRAIN DUST, SOLVENTS, THINNERS, OR OTHER FLAMMABLES.

⚠ WARNING: REPLACE WORN, DAMAGED, OR CUT ELECTRICAL CORDS AND PLUGS IMMEDIATELY.

⚠ WARNING: KEEP DRY; DO NOT EXPOSE TO RAIN OR SPRAY. FOR STORAGE, KEEP CHARGER IN A BUILDING. NE PAS EXPOSER A LA PLUIE.

AC INPUT

This battery charger must be grounded to reduce the risk of electric shock. It is equipped with an electric cord having an equipment-grounding conductor and a grounding-type plug. The plug must be plugged into an appropriate outlet that is properly installed and grounded in accordance with the National Electrical Code and all local codes and ordinances.

⚠ DANGER: IMPROPER CONNECTION OF THE GROUNDING CONDUCTOR CAN RESULT IN A RISK OF ELECTRIC SHOCK. DO NOT REMOVE GROUNDING PRONG FROM PLUG.

The conductor with insulation having an outer surface that is green, with or without yellow stripe(s), is the equipment-grounding conductor. If repair or replacement of the electric cord or plug is necessary, do not connect the equipment-grounding connector to a live terminal. Refer to a qualified service agent.

This battery charger is equipped with a grounding plug as illustrated in Figure A, for use on a nominal 120 volt, 60 Hertz circuit. A temporary adapter, as illustrated in Figures B and C, may be used to connect this plug to a two-pole receptacle as shown in Figure B if a properly grounded outlet is not available. The temporary adapter should be used only until a properly grounded outlet can be installed by a qualified electrician. The green-colored rigid ear extending from the adapter must be connected to a permanent ground such as a properly grounded outlet box.

⚠ DANGER: BEFORE USING THE ADAPTER AS ILLUSTRATED, BE CERTAIN THAT THE CENTER SCREW OF THE OUTLET PLATE IS GROUNDED.

GROUNDING METHODS

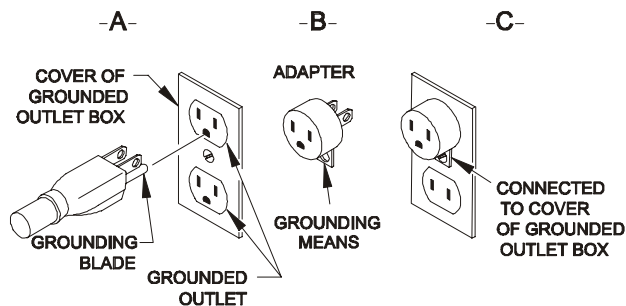

NOTE: Use of adapter shown in Figures B and C is NOT permitted in Canada.

NORMAL OPERATION

The instructions printed on the charger are for daily reference.

1. With the charger DC output cord disconnected from the batteries, connect the power supply cord to a 120 Volt, 60 Hertz outlet.

⚠ WARNING: TO REDUCE THE RISK OF AN ELECTRIC SHOCK, CONNECT ONLY TO A PROPERLY GROUNDED, SINGLE-PHASE (3-WIRE) OUTLET. REFER TO GROUNDING INSTRUCTIONS.

⚠ CAUTION: MAKE SURE THE BATTERY PACK IS A SERIES CONNECTED LEAD-ACID SYSTEM WITH A VOLTAGE AND CAPACITY RATING AS SHOWN IN SPECIFICATION TABLE ON PAGE ONE. THE FLOODED REPLACEABLE ELECTROLYTE DEEP-CYCLE BATTERY SETTING HAS AN ON-CHARGE VOLTAGE OF AT LEAST 2.50 VOLTS PER CELL. THE VALVE REGULATED GEL CELL OR SEALED DEEP-CYCLE BATTERY SETTING CHARGES TO A MAXIMUM ON-CHARGE VOLTAGE OF 2.38 VOLTS PER CELL. DAMAGE TO THE CHARGER AND BATTERIES MAY RESULT IF THIS CHARGER IS USED ON THE WRONG BATTERIES.

⚠ DANGER: RISK OF ELECTRIC SHOCK! DO NOT TOUCH UNINSULATED PARTS OF THE CHARGER OUTPUT CONNECTOR, BATTERY CONNECTOR, OR BATTERY TERMINALS.

⚠ DANGER: VISUALLY AND MANUALLY INSPECT TO VERIFY THAT THE DC OUTPUT CORDSET, PLUG AND BATTERY CHARGING RECEPTACLE ARE IN GOOD WORKING CONDITION BEFORE EACH AND EVERY USE AND DO NOT USE THE CHARGER IF:

- The DC charging receptacle does not grip the DC output plug tightly, is loose or does not make a good electrical connection.
- The DC output plug and/or charging receptacle feel hotter than normal.
- The DC output plug contacts or receptacle contacts are bent, corroded or are dark or bluish in appearance.
- The DC output plug, cords, receptacle or equipment charging wiring are cut, worn, broken, or have any exposed conductors.
- The DC output plug, cords, charger or receptacles are damaged or distressed in any way.

Using the charger with any of the above symptoms could result in a fire, property damage, or personal injury.

Have your distributor, dealer or other qualified service agent repair or replace worn or damaged parts immediately. Repairs should not be attempted by people who are not qualified.

2. Connect the DC output plug to the battery receptacle by grasping the plug body or handle and pushing the plug straight into the receptacle. The charger will start automatically in three to five (3-5) seconds.

⚠ WARNING: DO NOT DISCONNECT THE DC OUTPUT CORD FROM THE BATTERY RECEPTACLE WHEN THE CHARGER IS ON. THE RESULTING ARCING AND BURNING OF THE PLUG AND RECEPTACLE COULD CAUSE THE BATTERIES TO EXPLODE. IF THE CHARGER MUST BE STOPPED, FIRST DISCONNECT THE AC POWER SUPPLY CORD FROM ITS OUTLET, THEN DISCONNECT THE CHARGER DC OUTPUT PLUG FROM THE BATTERY RECEPTACLE.

3. Monitor the ammeter for the correct charge rate. The initial charge rate could vary several amps from the start current listed in the specifications, depending upon the condition of the batteries and how much the batteries have been discharged.

FLOODED ELECTROLYTE BATTERIES

During charge, the battery voltage increases gradually which causes the charge rate to decrease. Good battery cells should each rise to approximately 2.5 volts per cell DC which will allow the charge rate to taper to less than 10 amps. Since each cell accepts charge at a slightly different rate, normal charging with the ammeter reading in the 5 to 10 amps area for the last few hours of charge is important to achieve equalization of all battery cells every time the batteries are charged.

As batteries age, individual cells weaken resulting in lower than normal finish charge voltage. As the finish charge voltage decreases, the charge rate will no longer decrease and taper into the 5 to 10 amps range on the ammeter. The charger will, however, still determine when the batteries have reached full charge and turn off. Even though they are properly charged, older batteries will gradually lose capacity, and should be replaced when they will no longer perform as required.

VALVE REGULATED BATTERIES

During charge, the battery voltage increases gradually which causes the charge to decrease to near zero and remain there until the charger turns off. Gel cell deep-cycle batteries will still taper to near zero charge current even as they wear out and lose capacity and range. As sealed deep-cycle batteries lose capacity and range, the charge current may no longer decrease to this low a reading. The charger will still determine when the batteries are as charged as they are capable of being and turn off. When the batteries will no longer perform as desired, they should be replaced.

4. The charger turns off automatically when the batteries reach full charge. The necessary charge time is affected by numerous factors. The major factors affecting the required charge time are battery amp-hour capacity, depth of discharge, battery temperature and if the battery is new or broken in.
5. After the charger has turned off, disconnect the charger DC output plug from the battery receptacle by grasping the plug body or handle and pulling the plug straight out of the receptacle.

⚠ WARNING: TO AVOID DAMAGE TO THE CHARGER CORD, PLUG, AND BATTERY RECEPTACLE, DO NOT PULL ON THE CHARGER CORD. DO NOT TWIST, ROCK, OR PULL THE PLUG SIDEWAYS.

OFF-SEASON BATTERY STORAGE MAINTENANCE

When the equipment is not in use, the charger is designed to be left connected to the batteries with the AC power on. The charger will periodically provide a special refresh and conditioning charge to the batteries during long-term storage to help overcome battery self-discharge losses and to reduce sulfation.

Several charge cycles may be required to return the batteries to their full output after equipment has been in long term storage.

PROPER CARE OF DEEP CYCLE MOTIVE POWER BATTERIES

Motive power batteries are subjected to severe deep-cycle duty on a daily basis. Although these batteries are designed to withstand such duty, the following precautions must be observed to obtain good performance and maximum cycle life:

⚠ CAUTION: ALWAYS WEAR PROTECTIVE EYE SHIELDS AND CLOTHING WHEN WORKING WITH BATTERIES. BATTERIES CONTAIN ACIDS WHICH CAN CAUSE BODILY HARM. DO NOT PUT WRENCHES OR OTHER METAL OBJECTS ACROSS THE BATTERY TERMINAL OR BATTERY TOP. ARCING OR EXPLOSION OF THE BATTERY CAN RESULT.

1. When installing new batteries, be sure the polarity of each battery and overall battery pack is correct. Battery and/or charger damage can result.
2. New batteries should be given a full charge before their first use because it is difficult to know how long the batteries have been stored.
3. Limit the use of new batteries for the first 20 cycles. New batteries and older batteries that have been in storage are not capable of their rated output until they have been discharged and charged a number of times.
4. **DO NOT EXCESSIVELY DISCHARGE THE BATTERIES.** Excessive discharge can cause polarity reversal of individual cells resulting in complete failure shortly thereafter. Heavily discharging (over 60%) new batteries before they have been broken in (approximately 20 cycles) can cause permanent cell damage, resulting in reduced energy capacity and shortened life.
5. Maintain the proper electrolyte level of flooded electrolyte batteries by adding water when necessary. Distilled or deionized water is free of contaminants and preferred for this use. Never allow the electrolyte level to fall below the top of the battery plates. Electrolyte levels lower during discharge and rise during charge. Therefore, to prevent the overflow of electrolyte when charging, it is mandatory that water be added to cells **AFTER** they have been fully charged; do not overfill. Old batteries require more frequent additions of water than do new batteries.
6. Hard crystalline sulfates form when batteries in storage are not maintained in a charged active state. Internal self-discharge can bring about the start of this condition in as little as three days in warm temperatures. Batteries allowed to sit unmaintained in storage will self-discharge, sulfate to various degrees and lose capacity. Repeated charging without using the batteries between charges can recover some of the lost power, range, and life, but some permanent loss should be expected.

7. When the temperature falls below 65°F, the batteries should be placed on charge as soon after use as possible. Cold batteries require more time to fully recharge.
8. The tops of the batteries and battery hold-downs must be kept clean and dry at all times to prevent excessive self-discharge and flow of current between the battery posts and frame. Electrolyte spilled on the batteries never dries or evaporates.
9. All connections to batteries that are bolted must be maintained clean and bright. Due to heating and discharge rates, bolted connections loosen over time. Re-tighten the connections twice yearly to the manufacturer's specified torque.
10. Follow all operating instructions, cautions, and warnings as specified in this manual, on the charger, and in your vehicle owner's manual.

PERSONAL PRECAUTIONS

1. Someone should be within range of your voice or close enough to come to your aid when you work near a lead-acid battery.
2. Have plenty of fresh water and soap nearby in case battery acid contacts skin, clothing, or eyes.
3. Wear complete eye and clothing protection. Avoid touching eyes while working near battery.
4. If battery acid contacts skin or clothing, wash immediately with soap and water. If acid enters eye, immediately flood eye with running cold water for at least 10 minutes and get medical attention immediately.
5. **NEVER** smoke or allow a spark or flame in vicinity of battery.
6. Be extra cautious to reduce risk of dropping a metal tool onto battery. It might spark or short-circuit battery or other electrical part that may cause explosion.
7. Remove personal metal items such as rings, bracelets, necklaces, and watches when working with a lead-acid battery. A lead-acid battery can produce a short-circuit current high enough to weld a ring or the like to metal, causing a severe burn.
8. **NEVER** charge a frozen battery.

TROUBLESHOOTING GUIDE

To be able to troubleshoot safely and effectively, it is important to read this guide completely before beginning any tests.

⚠ CAUTION: DO NOT DISASSEMBLE THE CHARGER. TAKE IT TO A QUALIFIED SERVICE AGENT WHEN SERVICE OR REPAIR IS REQUIRED. INCORRECT REASSEMBLY MAY RESULT IN A RISK OF ELECTRIC SHOCK OR FIRE. THE FOLLOWING PROCEDURES ARE INTENDED ONLY TO DETERMINE IF A MALFUNCTION MAY EXIST IN THE CHARGER.

⚠ DANGER: TO REDUCE THE RISK OF ELECTRIC SHOCK, ALWAYS DISCONNECT BOTH THE POWER SUPPLY CORD AND THE OUTPUT CORD BEFORE ATTEMPTING ANY MAINTENANCE OR CLEANING.

⚠ WARNING: DO NOT OPERATE THE CHARGER IF IT IS MALFUNCTIONING. PERSONAL INJURY OR PROPERTY DAMAGE COULD RESULT.

To determine if a charger malfunction exists, identify the problem from the following list and refer to the appropriate section for detailed instructions.

1. CHARGER DOES NOT TURN ON
2. CHARGER FUSE BLOWS
3. CHARGER DOES NOT TURN OFF
4. THE BUILDING AC LINE CIRCUIT BREAKER OR FUSE BLOWS

If the problem is other than listed above, refer to a qualified service agent for additional troubleshooting procedures.

1. CHARGER DOES NOT TURN ON

The DC plug must be disconnected and reconnected to start or restart the charger after turn off.

Connect the power supply cord securely to a live AC outlet. Visually inspect the DC output plug and battery receptacle to be sure they are in good working condition.

⚠ WARNING: IF THE PLUG OR RECEPTACLE IS BROKEN, TWISTED, BENT OR LOOSE AND DOES NOT MAKE GOOD ELECTRICAL CONTACT, HAVE IT REPLACED BY A QUALIFIED SERVICE AGENT IMMEDIATELY. DO NOT USE THIS CHARGER IN THIS CONDITION AS FIRE OR PERSONAL INJURY CAN RESULT.

If the plug and receptacle are good, connect the DC plug into the receptacle and listen for the power relay inside the charger to "click" on within five

seconds. If the "click" is not heard remove the DC plug from the receptacle and connect the DC plug of another charger, which you know is operating properly, to the receptacle.

If still no "click" is heard, a malfunction in the batteries or receptacle wiring exists. If the "click" is heard, the batteries and receptacle are good, and a malfunction exists in the original charger.

If the relay "click" is heard, a hum from the transformer should be heard and the ammeter should indicate the charge rate. If no transformer hum is heard, check to be sure the AC power supply cord is securely connected to a live AC outlet. When three-prong to two-prong adapters are used, they tend to work loose, resulting in a poor connection. Check the AC line fuse or circuit breaker and, if possible, connect a functioning charger, utility light, or other electrical appliance to the outlet to verify the presence of AC power. If AC power is present, and still no transformer hum is heard, the charger is malfunctioning.

If the relay "clicks" and the transformer hums, but no charge rate is indicated on the ammeter, the charger is malfunctioning.

2. CHARGER FUSE BLOWS

The charger fuse assembly consists of a fuse wire with a transparent cover visible on the front of the charger. The fuse link protects the charger in the event the SCR or transformer fails.

Check the fuse assembly visually for an open or blown fuse link. If the fuse assembly blows as soon as the DC output plug is connected to the battery receptacle, the charger is malfunctioning.

3. THE CHARGER DOES NOT TURN OFF

New batteries or batteries charged in cold temperatures may require an extended charge time to achieve full charge. The charger implements a 20 hour maximum timer to protect the system. If the charger runs for more than 20 hours without shutting off, the charger is malfunctioning.

4. THE BUILDING AC LINE CIRCUIT BREAKER OR FUSE BLOWS

This condition can be caused by a charger problem, a "weak" fuse or circuit breaker protecting the circuit, or an overloaded circuit. If the building AC power fuse or circuit breaker blows, connect the charger to other outlets (on different circuits) in the building. If the charger operates properly on other circuits, have a qualified electrician inspect and test the original circuit. If the charger causes other fuses or circuit breakers (in the building) to blow, the charger should be tested for a problem.

EXPLODED VIEW

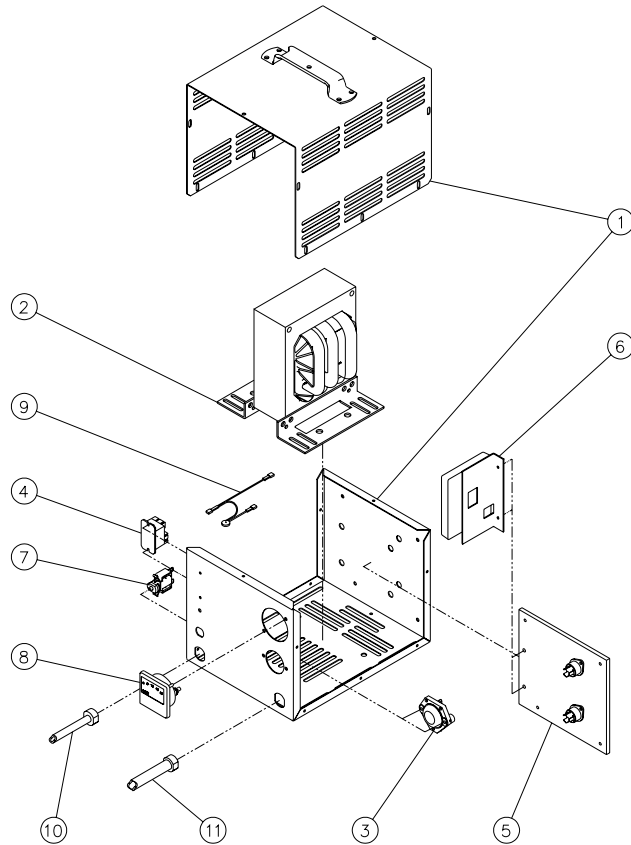

35326FIG002_C

SERVICE PARTS LIST

#	Service Part Description	25910 24V 21A	25920 24V 25A	25900 36V 21A	25890 36V 25A	25930 48V 17A
1	Case assembly	35474S	35476S	35473S	35392S	35477S
2	Transformer assembly	25915S	25925S	25905S	25895S	25935S
3	Fuse assembly	08776S	08776S	08776S	08776S	08776S
4	Relay	24228S	24228S	21237S	21237S	21238S
5	Heatsink assembly w/ SCR's & wires	35394S	35394S	35394S	35394S	35394S
6	Electronic controller assembly	25685S	25675S	25655S	25645S	25855S
7	AC circuit breaker	31847S	31847S	34882S	34882S	34882S
8	Ammeter	21461S	16369S	21461S	16369S	16895S
9	AC surge suppressor	35554S	35554S	35554S	35554S	35554S
10	AC cordset, 5-15P plug & bushing	21307-08S	21307-08S	21307-08S	13072-08S	21307-08S
11	DC cordset, Lester rubber 2 blade plug	14973-08S	14973-08S	14973-08S	14973-08S	N/A
11	DC cordset, SB50 gray plug	08607-08S	08607-08S	08607-08S	08607-08S	08607-08S
11	DC cordset, SB50 red plug	24234-08S	24234-08S	24234-08S	24234-08S	24234-08S
11	DC cordset, SB175 gray plug	08224-08S	08224-08S	08224-08S	08224-08S	08224-08S
11	DC cordset, SB175 red plug	28376-08S	28376-08S	28376-08S	28376-08S	28376-08S
11	DC cordset, Lester plastic 2 blade plug, yellow	08020-08S	08020-08S	08020-08S	08020-08S	08020-08S
11	DC cordset, Lester plastic 2 blade plug, black	N/A	N/A	N/A	N/A	35963-08S
11	DC cordset, SB50 red plug w/ key	N/A	35664-08S	N/A	N/A	N/A
11	DC cordset, SB50 gray plug w/ key	N/A	N/A	N/A	28077-08S	N/A

DO NOT DISASSEMBLE THE CHARGER.

TAKE IT TO A QUALIFIED SERVICE AGENT WHEN SERVICE OR REPAIR IS REQUIRED.

WIRING DIAGRAM

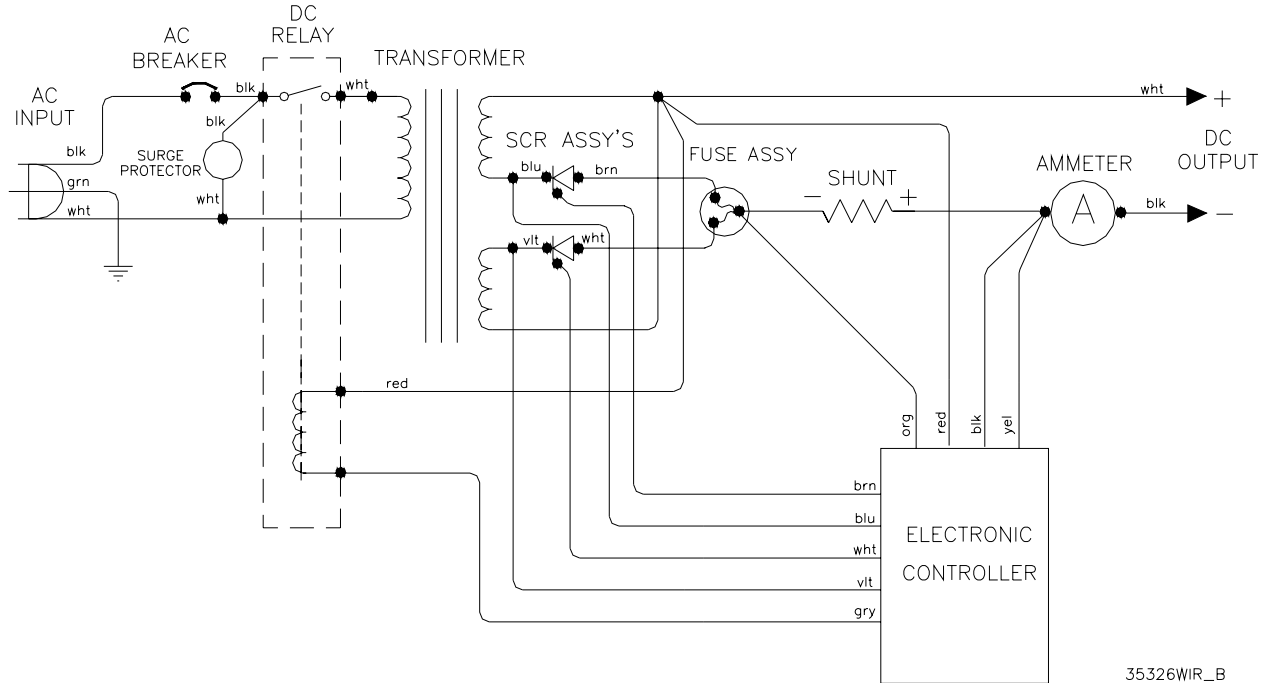

WARRANTY

Lester Electrical warrants each new Lester Battery Charger for defects in material and workmanship for a period of two (2) years from the date of manufacture of the complete unit.

Repairs can be made at the Lester Electrical factory. To do so, FIRST obtain a "Return Material Authorization" number by calling the Service Department of Lester Electrical (**402 477-8988**) or by e-mailing service@lesterelectrical.com and send the defective unit with transportation charges prepaid to:

Lester Electrical
625 West A Street
Lincoln, NE 68522-1794 USA
Attention: Service Department
RMA # _____

For repairs made at other than the Lester Electrical factory, Lester will provide only the replacement parts. Defective parts should be sent with transportation charges prepaid to the Lester Electrical factory at the address noted above.

If the unit or parts are found, in the reasonable judgment of Lester Electrical, to be defective in material or workmanship, repair, or replacement will be made by Lester Electrical without charge for parts or labor. Repair or replacement will be at the discretion of Lester Electrical, with replacements being made using current models or parts performing the equivalent function. Labor charges other than those incurred at the Lester Electrical factory are not covered under this warranty. All expenses associated with delivering defective items to the Lester Electrical factory and the expense of returning repaired or replaced items from the Lester Electrical factory to the owner will be paid for by the owner. All warranty work accomplished at the Lester Electrical factory will be completed within a reasonable time after receipt of defective items.

This warranty does not cover any semiconductor parts, such as diodes, which are vulnerable to electrical overloads beyond the control of Lester Electrical. Warranty on parts not manufactured by Lester Electrical, which include, but are not limited to, timers and ammeters is limited to the period specified in the original manufacturer's warranty.

This warranty does not cover any charger that has been subject to misuse, neglect, negligence, or accident, or operated in any way contrary to instructions specified on the charger case and in the owner's manual. No claim of breach of warranty shall be cause for cancellation of the contract of sale of any Lester Electrical charger. Lester Electrical assumes no responsibility for loss of time, inconvenience, or other damage, consequential or otherwise, resulting from a defective charger. All implied warranties (including merchantability) are limited in duration to two (2) years from date of manufacture warranty period.

Some states do not allow the exclusion or limitation of incidental or consequential damages, or limitations on how long an implied warranty lasts, so the above limitations may not apply to you. This warranty gives you specific legal rights, and you may also have other rights which vary from state to state.

Lester Electrical's obligation under this warranty is strictly and exclusively limited to the repair or replacement of defective items. Lester Electrical issues this warranty in good faith and with full confidence in the workmanship and quality of Lester Electrical products.