

OEM Installation of the PM3 Series Power Center

Select a mounting location near the shore power and battery (batteries).

- Do not mount in an area where the owner may store items, as this could reduce the clearance requirements, obstruct ventilation openings and affect the efficient operation of the converter.
- Do not install close to appliances that are a source of heat or water (such as water heaters, furnaces, and under refrigerators). It is not designed for mounting in wet locations. It must be protected from direct contact with water.



This equipment employs components that tend to produce arcs or sparks.

To prevent fire or explosion,

DO NOT INSTALL IN COMPARTMENT CONTAINING BATTERIES OR FLAMMABLE MATERIALS (LP gas).



FOR CONTINUED PROTECTION AGAINST RISK OF FIRE, REPLACE ONLY WITH THE SAME TYPE AND RATING FUSE. The fuse rating which the manufacturer suggests for the output fuses will be marked on the unit. Replace only with same type and rating.

During the manufacturing process, be sure that all converter openings are protected from debris falling into the unit. **This is a non-warranty item.**

NOTE: If the reverse battery protection fuses are blown during installation, be sure that the battery has been connected properly, then replace the fuses with ATC "Littelfuse" Type 257 with the same rating as the original.

General Consumer Information

Reverse Battery Protection

This feature prevents permanent damage to the converter from an incorrect battery connection.

- **Automatic Cooling Fan**

The fan is variable speed and current controlled.

- **Electronic Current Limiting**

Automatically shuts down power during overload or short-circuit conditions.

Automatically returns to normal operation after conditions are corrected.

- **DC Fuses**

Reverse battery protection fuses; replace only with ATC "Littelfuse" Type 257 fuse.

- **Lightweight**

- 35 A unit weighs only 9.03 lbs.
- 45 A unit weighs only 11.20 lbs.
- 55 A unit weighs only 11.57 lbs.
- 65 A unit weighs only 14.33 lbs.
- 75 A unit weighs only 14.88 lbs.

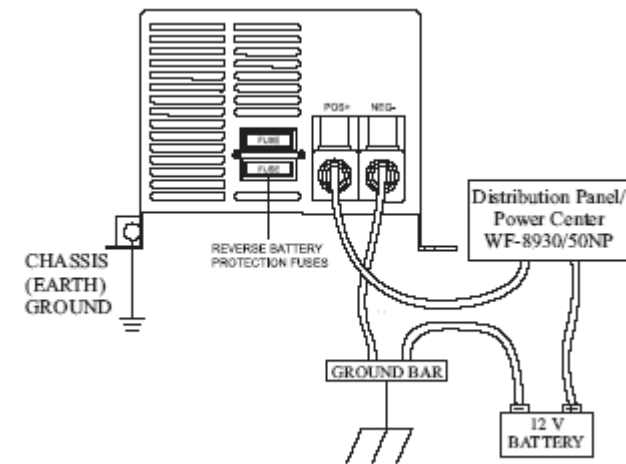

PM3 Series Converter Dimensions

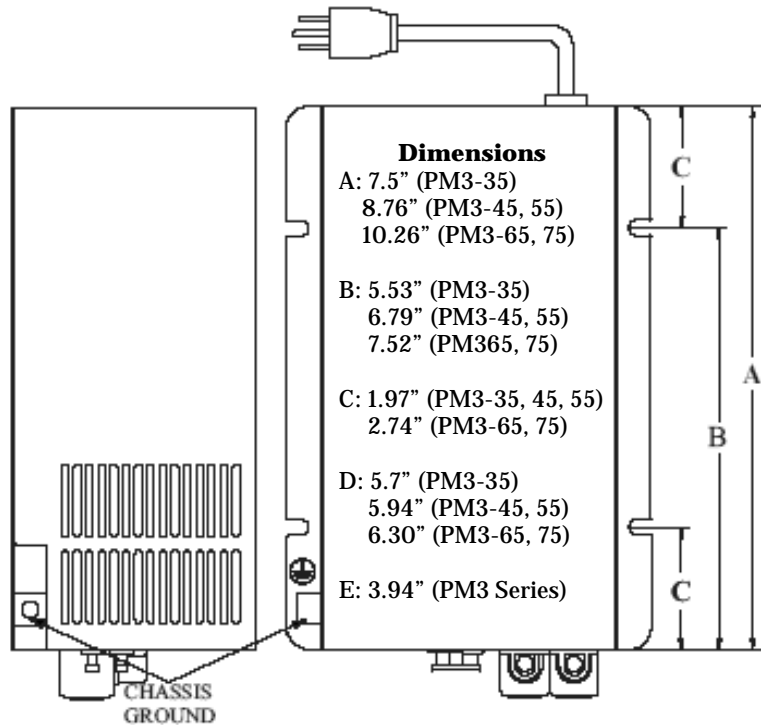

Reverse Polarity Fuses Used:

- PM3-35—35 Adc
- PM3-45—30/30 Adc
- PM3-55—35/35 Adc
- PM3-65—40/40 Adc
- PM3-75—40/40 Adc

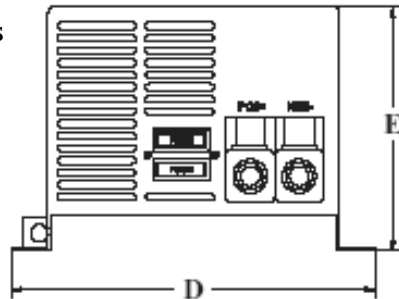

PM3 Series Specifications

Output Load Curve

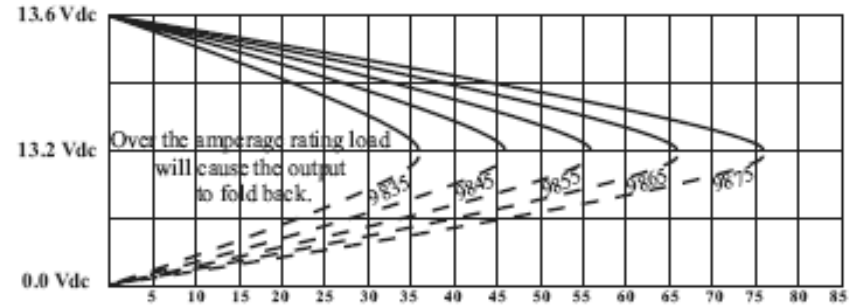

PM3 Series Facts Summary

Model No.	AC Input		DC Output		Dimensions			Weight (lbs)	Fan Cooled
	Voltage (V)	Current (A)	Volts (V)	Amps (A)	Height (in)	Width (in)	Length (in)		
35	120 Vac 60 Hz	7.4	Bulk Charge Mode: 14.4 Vdc, 4hr max.	35	3.94	5.70	7.48	9.03	Yes
45		9.5		45		5.94	8.66	11.2	
55		11.5	Absorption Mode: 13.6 Vdc	55		5.94	8.66	11.57	
65		13.9	Float Mode: 13.2 Vdc	65		6.30	10.27	14.33	
75		15.7		75		6.30	10.27	14.88	

Converter Operation Modes

All PowerMax power converters are automatic three-stage switching power supplies. The converter senses which mode it needs to be in by checking the RV system voltage.

The three modes/stages of operation include:

Absorption mode/Normal operation

Nominal battery charge and supplies power to appliances

Bulk mode/Charge mode

Fast battery charge and supplies power to appliances

Float mode/Trickle charge

Trickle battery charge during storage

Absorption Mode: During this mode, the converter output is in the 13.6 Vdc range. This is the normal operation mode. This mode provides the 12 Vdc and current required by the 12 Vdc RV appliances, as well as slow charging the battery.

Bulk Mode: When the converter senses that the RV system voltage is less than 13.2 Vdc (equivalent to less than 50% of battery charge) the converter will automatically go into the “Bulk mode.” In this mode, the output voltage of the converter will switch to 14.4 Vdc for a maximum of four hours. If the converter cycles between “Absorption and Bulk mode,” there could be a shorted battery cell or other issues.

If the output voltage drops below 13.2 Vdc, the converter automatically changes to a “Bulk mode” 14.4 Vdc (unless the converter is in overload condition). There are two signs of an overloaded converter:

Low output voltage, and full converter fold back or shutdown. In both cases, the converter will automatically turn ON, once the complete load

is removed. For low output condition, removing the extra (over the current rating) load will be sufficient. If it is impractical to remove all the load, resetting the main breaker will have the same effect.

Float Mode: If the RV is not being used for approximately 48 hours, with a “no load” condition and the shore power is plugged in, the converter will automatically go in to the “Float mode.” In this mode, the converter is charging the battery with a trickle voltage of 13.2 Vdc. When the converter senses a demand (by turning on lights), the converter automatically returns to the “Absorption mode” 13.6 Vdc.

Troubleshooting PM3 Series Converter

If the input from shore power is 105 Vac-130 Vac to the receptacle, check the reverse battery protection fuse on the front plate of the PM3 deck mount converter. Visually inspect the fuses for any breaks/opens. If the fuses do not appear to be open, use a tester to check for continuity.

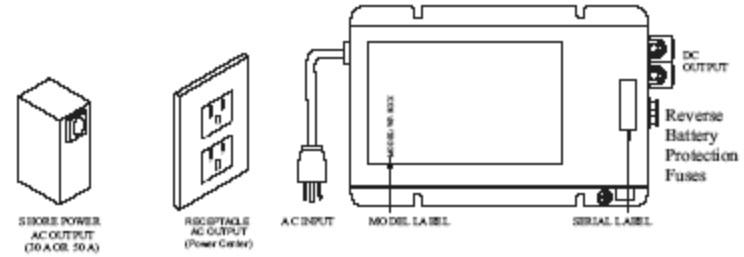

If the reverse polarity fuses are blown, it means the RV battery was accidentally connected in reverse, either at the battery or at the converter. Reconnect properly, then replace the fuse with the same type and amp rating as the original “Littelfuse” Type 257 automotive style fuse.

IMPORTANT: These fuses protect the converter from damage in the event that the RV battery is accidentally connected in reverse. A reverse battery connection, even for a second, is the only reason that these fuses will blow.

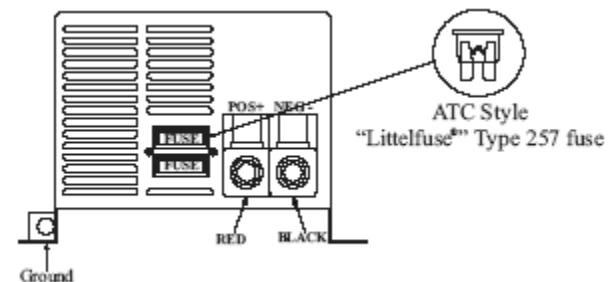

WF-9800 Series Troubleshooting

Before the converter output voltage can be checked, it is necessary to disconnect both DC output wires from the converter (as shown below). Use a 5/16 hex driver to disconnect the wires. Cover each wire with electrical tape to prevent shorts. Plug the converter into a 120 VAC source. Using a voltmeter, check the converter output voltage.

Place the **Positive** + (red) probe in the **POS** + output (red) and place the **Negative**- (black) test probe into the **NEG**- (black) output terminal of converter. Be sure you have good connections at the terminals. If the voltage reads 13.6 Vdc (+/- 0.2 volts), the converter is functioning properly.

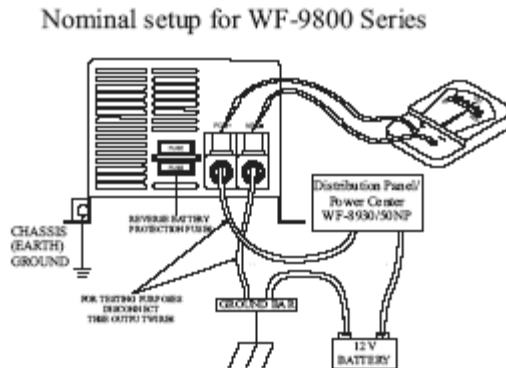

If the converter output voltage reads in the 13.6 Vdc range and the battery is not charging, check for:

- an open inline fuse in the battery wire (if provided)
- an open wire between the converter and the RV battery
- loose ground
- improper torques

If the converter fuses and AC voltage are good, but the converter output still reads zero volts, the converter is not functioning properly.

GENERAL COMPLIANCE INFORMATION

The PM3 Series units are UL-Listed, and cUL-Listed (Canadian). They comply with FCC Class B requirement (see below)

FCC Compliance Class B

NOTE: This equipment has been tested and found to comply with the limits for a Class B digital device, pursuant to Part 15 of the FCC Rules. These limits are designed to provide reasonable protection against harmful interference when the equipment is operated in a commercial environment. This equipment generates, uses, and can radiate radio frequency energy and, if not installed and used in accordance with the instruction manual, may cause harmful interference to radio communications. Operation of this equipment in a residential area is likely to cause harmful interference in which case the user will be required to correct the interference at his own expense.